

Cost effectiveness of policy options for boilers - Kaiapoi

Report No. U07/96

ISBN: 978-1-86937-761-8

**Prepared by Emily Wilton, Brian
Anderson and John Iseli.**

October 2007

The information in this report is accurate to the best of the knowledge and belief of the Consultant acting on behalf of Environment Canterbury. While the Consultant has exercised all reasonable skill and care in the preparation of information in this report, neither the Consultant nor Environment Canterbury accept any liability in contract, tort, or otherwise for any loss, damage, injury or expense, whether direct, indirect, or consequential, arising out of the provision of information in this report.

Report No. U07/96
ISBN: 978-1-86937-761-8

58 Kilmore Street
P O Box 345
CHRISTCHURCH
Phone: (03) 365 3828
Fax: (03) 365 3194



75 Church Street
P O Box 550
KAIAPOI
Phone: (03) 684 0500
Fax: (03) 684 0505

Website: www.ecan.govt.nz
Customer Services Phone 0800 324 636

Executive summary

Concentrations of PM₁₀ in Kaiapoi exceed the Ministry for the Environment's (MfE) National Environmental Standard (NES) of 50µg m⁻³ (24-hour average). The number of NES breaches in Kaiapoi range from 17 to 40 per year and compares with an allowable one breach per year. The number of NES breaches and the maximum PM₁₀ concentrations vary from year to year, depending largely on variations in meteorological conditions. A 68% reduction in PM₁₀ concentrations is required for Kaiapoi to meet the NES based on 2006 monitoring results (Scott & McCauley, 2007).

The Air Quality Chapter of Environment Canterbury's Natural Resource Regional Plan contains measures to manage air quality in Kaiapoi. These include restrictions on the installation of new woodburners in Kaiapoi to burners that meet specific emissions criteria and requirements relating to obtaining resource consents for industrial discharges. This plan is scheduled to become operative during 2007. An assessment of the impact of the status quo on PM₁₀ emissions in Kaiapoi indicates that the NES for PM₁₀ will not be met in the absence of additional air quality management (Scott & McCauley, 2007).

To develop a strategy for achieving the required reductions, Environment Canterbury require further information on the cost effectiveness of different management options for reducing PM₁₀.

This report evaluates the costs and benefits of regulations targeting industrial and commercial boilers in Kaiapoi. Four policy options were examined. These required boiler particulate matter emissions to meet the each of the following emission limits: 300 mg/m³, 250 mg/m³, 150 mg/m³ and 50 mg/m³.

The main source of PM₁₀ emissions in Kaiapoi is domestic heating with the 2004 inventory indicating that industry contributes only 1% (5 kilograms) of the daily winter PM₁₀. The baseline emissions assessment for this study for 2006 suggests that the industrial contribution in Kaiapoi is around 12% less than predicted in the 2006 inventory, and is therefore still minimal (1% of the total). Because of this low contribution, measures targeting industry in Kaiapoi are unlikely to be an effective way of achieving the reductions required.

Costs were assessed for capital expenditure and ongoing operation and were expressed as net present value for 2006 based on a discounted cash basis of 6%. Existing boilers in Kaiapoi are able to comply with the 300mg/m³ emission limit without additional costs. Of the remaining options, the most cost effective for industry was setting an emission limit of 250 mg/m³. This resulted in a 27% reduction in PM₁₀ emissions relative to the baseline predictions for 2013. The costs and benefits of each of the policy options are shown in the following Table.

	Total cost	Reduction in PM ₁₀ (kg/day) winter	Cost \$ per kg reduction in PM ₁₀
Policy 300 mg/m ³	\$ 3,990	-	
Policy 250 mg/m ³	\$ 113,642	2	\$ 63,220
Policy 150 mg/m ³	\$ 339,229	4	\$ 78,713
Policy 50 mg/m ³	\$ 337,069	5	\$ 65,110

Table of Contents

Executive summary	1
1 Introduction	7
2 Methodology	9
2.1 Identify and survey industry	9
2.2 Boiler profiles and baseline emissions.....	10
2.2.1 Boiler profile 2006	10
2.2.2 Boiler profile 2013	10
2.2.3 Emission estimates 2006	10
2.2.4 Emission estimates 2013	10
2.3 Policy options analysis	11
3 Baseline data – 2006 and 2013	11
4 Least cost options for meeting the emission limits	13
5 Reductions in emissions	17
6 Cost effectiveness	18
7 Conclusion	19
8 Acknowledgements	20
References	21
Appendix A: Industrial Emission Survey Form	22
Appendix B: Emission Rates for Industrial Boilers	25
Appendix C: Cost data	32
Appendix D: Notes for implementation	33
Appendix E: Summary Boiler Information	34
Appendix F: Boiler technology	35
Boilers	38
Sectional Boilers.....	38
Shell and Tube boilers, multi-pass	38
Shell and Tube Reverse Pass Boilers	39
Vertical Shell and Tube	40
Water Tube Boilers	40
Waste Heat Boilers	41
Tubular Gas Boilers	41
Condensing Boilers	41

Burners	43
Underfeed Stokers	43
Drop Tube Stoker	44
Spreader Stoker	44
Chain-grate Stoker	45
Pressure Jet Burner	46
Air-atomised Burners	47
Rotary Cup Burners	47
Pressure Jet Gas Burners	47
Naturally Aspirated Burners	48

Appendix G: Reducing boiler emissions 49

Operation and maintenance	49
Energy Efficiency Measures	49
Fuel Conversions	50
Coal to Light Distillate Oil (also known as Diesel or Number 2 Oil)	50
Coal to Light Fuel Oil	51
Coal to Wood Pellets	51
Coal to Wood Waste	51
Coal to Gas (LPG)	51
Light Fuel Oil to Light Distillate Oil	51
Oil to Gas	52
Heat Pumps	52
Add-On's	52
Cyclones	53
Wet Scrubbing	54
Bag Filters	54
Electrostatic Precipitators	55
Ceramic Filters	56
Future Possibilities	57
Gasification	57

List of Figures

Figure 1.1 Map of Kaiapoi Airshed	8
Figure 3.1: Comparison of revised 2006 baseline emissions to 2004 inventory assessment	12
Figure 3.2: Industrial combustion PM ₁₀ emissions by source – 2006 and 2013	13
Figure 5.1: Daily PM ₁₀ from coal-fired boilers in Kaiapoi from 2006 to 2013	17
Figure 5.2: Baseline and policy option 2 (250 mg/m ³) 2013 combustion PM ₁₀ emissions by individual boiler	18

List of Tables

Table 3.1: Summary baseline 2006 boiler data for Kaiapoi.....	11
Table 4.1: Least cost options (LCO) for meeting emission limits	16
Table 5.1: Reductions in PM ₁₀ emissions.....	18
Table 6.1: Cost effectiveness of policy options - all boilers.....	19

1 Introduction

Air quality in Kaiapoi exceeds the National Environmental Standard (NES) for PM₁₀ of 50µg m⁻³ (24-hour average) frequently during the winter months. The highest measured PM₁₀ concentration in Kaiapoi was 163µg m⁻³ (24-hour average) and was measured during 2003. Environment Canterbury indicates that a 68% reduction in PM₁₀ concentrations is required for Kaiapoi to meet the NES (Scott & McCauley, 2007). This is based on the second highest¹ 24-hour average PM₁₀ concentration measured during 2006 of 146µg m⁻³. A map of the Kaiapoi airshed is shown in Figure 1.1.

An emission inventory for Kaiapoi (McCauley and Scott, 2006) indicates solid fuel burning for domestic home heating is the main source of winter PM₁₀ emissions contributing 95% of the daily winter emissions. Industry in Kaiapoi was estimated to contribute 1% with motor vehicles contributing 4% of the daily winter PM₁₀ emissions.

The Air Quality Chapter of Environment Canterbury's Natural Resource Regional Plan contains measures to manage air quality in Kaiapoi. These include restrictions on the installation of new woodburners in Kaiapoi to burners that meet specific emissions criteria and requirements relating to obtaining resource consents for industrial discharges. This plan is scheduled to become operative during 2007. An assessment of the impact of the status quo on PM₁₀ emissions in Kaiapoi indicates that the NES for PM₁₀ will not be met in the absence of additional air quality management (Scott & McCauley, 2007).

If the NES is not met by 2013, Environment Canterbury will be unable to grant resource consents for discharges to air in the Kaiapoi airshed. In addition, between September 2005 and 2013 a resource consent for a PM₁₀ discharge in Kaiapoi can only be granted if the Council can demonstrate a "straight-line path" (SLiP) to compliance that will not be impinged on by the granting of the consent. This applies only if the proposed discharge is likely to result in a "significant" increase in PM₁₀ concentrations. If non-compliance with the SLiP occurs, industry may offset their discharge by obtaining reductions in emissions from other sources (MfE, 2005). However, post 2013, the "significance" test and ability to offset emissions no longer applies and all consents with PM₁₀ discharges must be declined.

Thus if Environment Canterbury are to be able to grant resource consents in the Kaiapoi airshed after 2013, PM₁₀ concentrations need to be reduced by around 68%. A range of approaches could be used to allocate the reduction in PM₁₀ across the different sources contributing to these concentrations. These include:

1. Equal percentage reduction in emissions from each sector
2. Reduction by sources in proportion to their relative contribution to PM₁₀ in 2006
3. Reduction by the domestic sector alone – no reduction required for industry
4. Reductions for industry using Best Practicable Option (BPO) or Best Available Control Technology (BACT)
5. Reductions based on relative cost effectiveness
6. Reductions based on equal allocation of airshed capacity at 2013

Environment Canterbury is currently gathering information on the costs and effectiveness of management options targeting both domestic heating and industry in Kaiapoi. This report evaluates the costs and the effectiveness of setting emission limits for industrial boilers in reducing PM₁₀ emissions in Kaiapoi. The four total suspended particulate (TSP) emission limits² evaluated are 300 mg/m³, 250 mg/m³, 150 mg/m³ and 50 mg/m³.

¹ The second highest value was used because the NES allows for one breach of 50 µg m⁻³ per year.

² All particulate matter emission concentrations in mg/m³ stated in this report have been adjusted to standard conditions (101.3kPa, 0 degrees Celsius, 12% CO₂, dry gas basis).



Figure 1.1 Map of Kaiapoi Airshed

2 Methodology

The following task schedule describes the process used to establish the cost effectiveness of setting emission limits for boilers in Kaiapoi.

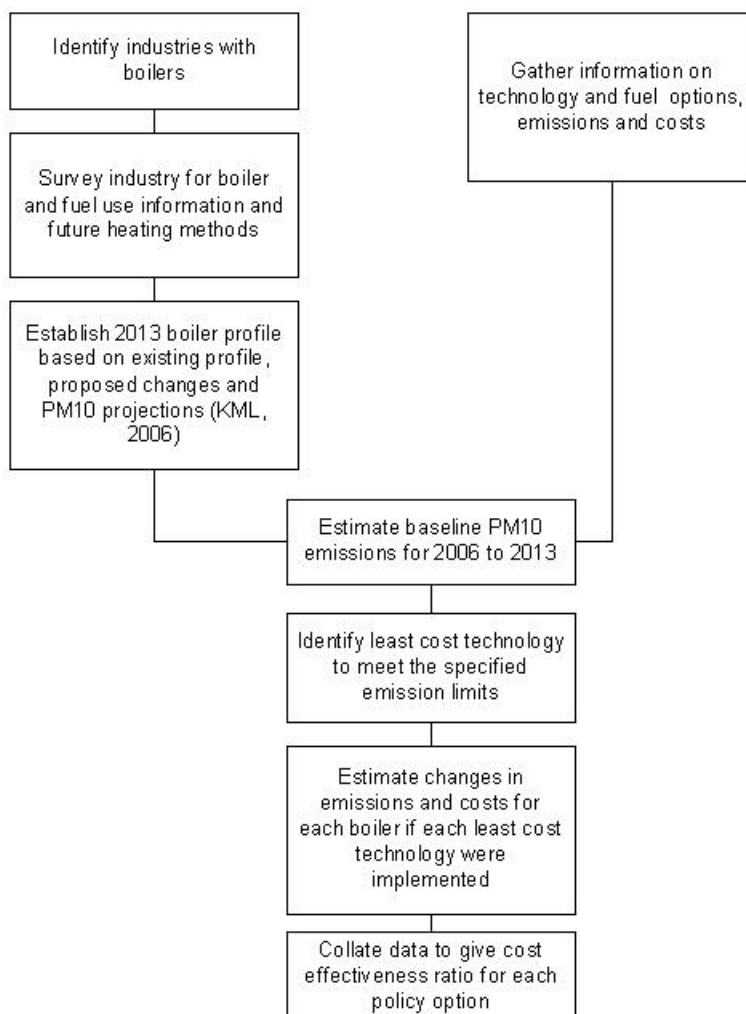

2.1 Identify and survey industry

Industrial and commercial boilers were identified based on a list of air discharges used in the 2004 air emission inventory assessment, which was provided by Environment Canterbury. This list had been generated by Environment Canterbury staff based on information in the resource consent database, phone books and other information, such as school lists for the area. This list was updated based on additional information provided on consents granted post 2004, current applications and consents that had been withdrawn or surrendered.

Information on the existing boiler design, fuel consumption, emissions control and seasonal variations in fuel use were obtained from these industrial and commercial activities using a mail survey (Appendix A). Follow up phone calls were made to assist with completing the survey.

2.2 Boiler profiles and baseline emissions

2.2.1 Boiler profile 2006

The 2006 boiler profile was established based on a list of industry and contact details provided by Environment Canterbury. These industries were then surveyed, initially using a hard copy of the industry survey by post then with a follow up phone call a week later. The survey collected information on fuel types, boiler types, emission control technology and fuel consumption and is detailed in Appendix A.

2.2.2 Boiler profile 2013

The 2013 boiler profile updated the 2006 profile based on information gathered in the survey on proposed changes before 2013.

In addition, consideration was given to new boilers that might be commissioned between 2006 and 2013. KML (2006) predicted increased future energy consumption and PM₁₀ emissions for a number of urban areas of Canterbury. Key information or assumptions from KML (2006) were:

- Breakdown of future energy use by fuel type based on trends for Canterbury (excluding Christchurch) from 1982 to 2002.
- Changes in annual fuel consumption from 2002 to 2013 for wood, coal and oil.

The 2013 boiler profile could have been estimated based on information provided in KML (2006) and an assessment of the likely future industry in the area and current industry preferences for heating methods. However, the KML projections rely on the assumption that the distribution of future energy choices between fuels will be similar to the current situation. This is not reflected in current market choices, particularly for smaller scale space heating activities, which show a preference for heat pump technology over coal burners.

Predicting the types and scale of new industry going into a location will always be a bit of a lottery. However, in our view, the likelihood of a type of large scale industry that might install a coal-fired boiler setting up in Kaiapoi is slim. Existing industrial scale sources are school boilers and a wood fired boiler used in the wood products industry.

One new wood fired boiler (Vekos) was assumed to be installed in Kaiapoi in 2008. This was based on information from the survey which indicated an expansion and new boiler at the existing industry location. The annual fuel consumption was assumed to be 375 tonnes per year based on information provided by the industry.

2.2.3 Emission estimates 2006

The 2006 winter daily baseline emissions (kg/day) were estimated based on the fuel use data collected for the survey and the emission factors summarised in Appendix B. It should be noted here that the emission factors used here are generally lower than USEPA emission rates used in the emission inventory for Kaiapoi (McCauley & Scott, 2006).

No process (non combustion) sources were included in the 2004 inventory for Kaiapoi.

The emissions were expressed as kilograms of PM₁₀ per winter weekday.

2.2.4 Emission estimates 2013

Emission estimates from the industrial boilers for 2013 were made using the boiler profiles for 2013, the 2006 fuel consumption data for existing industry and the projected percentage increase in fuel use for "new" boilers.

It was assumed that there would be no change in the process PM₁₀ emissions (none identified for 2004) from 2004 to 2013.

Emissions were expressed as kilograms of PM₁₀ per winter weekday.

2.3 Policy options analysis

Boilers were classified based on generally agreed industry classifications using information gathered in the survey on boiler make, model, and size, burner make, model and size.

An estimate of indicative emission rates was made for each classification (mg/m^3). An assessment of indicative baseline operating costs was made for each industry based on fuel use information collected during the survey and fuel cost data obtained from suppliers.

The measures available to achieve the four emission standards (50, 150, 250 and $300 \text{ mg}/\text{m}^3$) were assessed for each of the boiler classifications. The costs associated with these changes were estimated based on consultation with boiler manufacturers and fuel cost data. Operating costs were based on an estimate of the heat requirements derived from survey data on fuel use.

For each site, any likely additional emission reduction (i.e., lower than the specified limit) that might occur as a result of the technology was also identified and used as the basis for evaluating improvements in PM_{10} .

Costs were estimated for each year from 2006 to 2013 and included the capital costs of the conversion and annual operating costs. The capital cost of conversion was assumed to occur entirely within the year of implementation, which was assumed to be 2012. To allow for the changing value of money all costs were expressed as the net present value (NPV)³ for 2006 based on discounting of 6%.

An estimate of the revised winter daily PM_{10} emissions (kg/day) was made for each site for each emission limit. This was based on the reductions in emission concentration for each of the technology options. The reduction in emissions associated with each emission limit was calculated across the whole airshed relative to the business as usual (BAU) emission estimate for 2013.

3 Baseline data – 2006 and 2013

Baseline data for both emissions and costs was required from 2006 to 2013. This allowed for an assessment of changes in emissions and costs associated with the implementation of policy options. Baseline data for 2006 included the boiler profiles, estimates of emissions, estimates of costs and process emissions for 2006. Table 3.1 shows summary data for 2006. Emission estimates are based on emission factors detailed in Appendix B and costs detailed in Appendix C.

Baseline emission estimates for 2006 and 2013 included estimates of emissions from diesel and LPG boilers. As detailed in Appendix B these boiler types were not included in the policy options assessment because emissions test results indicate compliance with the lowest policy option considered here ($50 \text{ mg}/\text{m}^3$). Summary boiler information for these types of activities is therefore not included.

Table 3.1: Summary baseline 2006 boiler data for Kaiapoi

Boiler Classifications	No.	Inventory PM_{10} kg/day	Revised 2006 PM_{10} (kg/day)	2013 PM_{10} (kg/day)	2006 Operating Costs \$
Wood Vekos	1	2.6	1.9	1.9	6,000
Underfeed stoker	3	2.2	2.4	2.4	16,950

³ NPV compares the value of a dollar today to the value of that same dollar in the future, taking inflation and returns into account.

The Environment Canterbury Resource Consent database indicated no new industrial activities since the 2004 air emission inventory. Emission estimates for 2006 for Kaiapoi were similar to the 2004 emission inventory estimates (Figure 3.1).

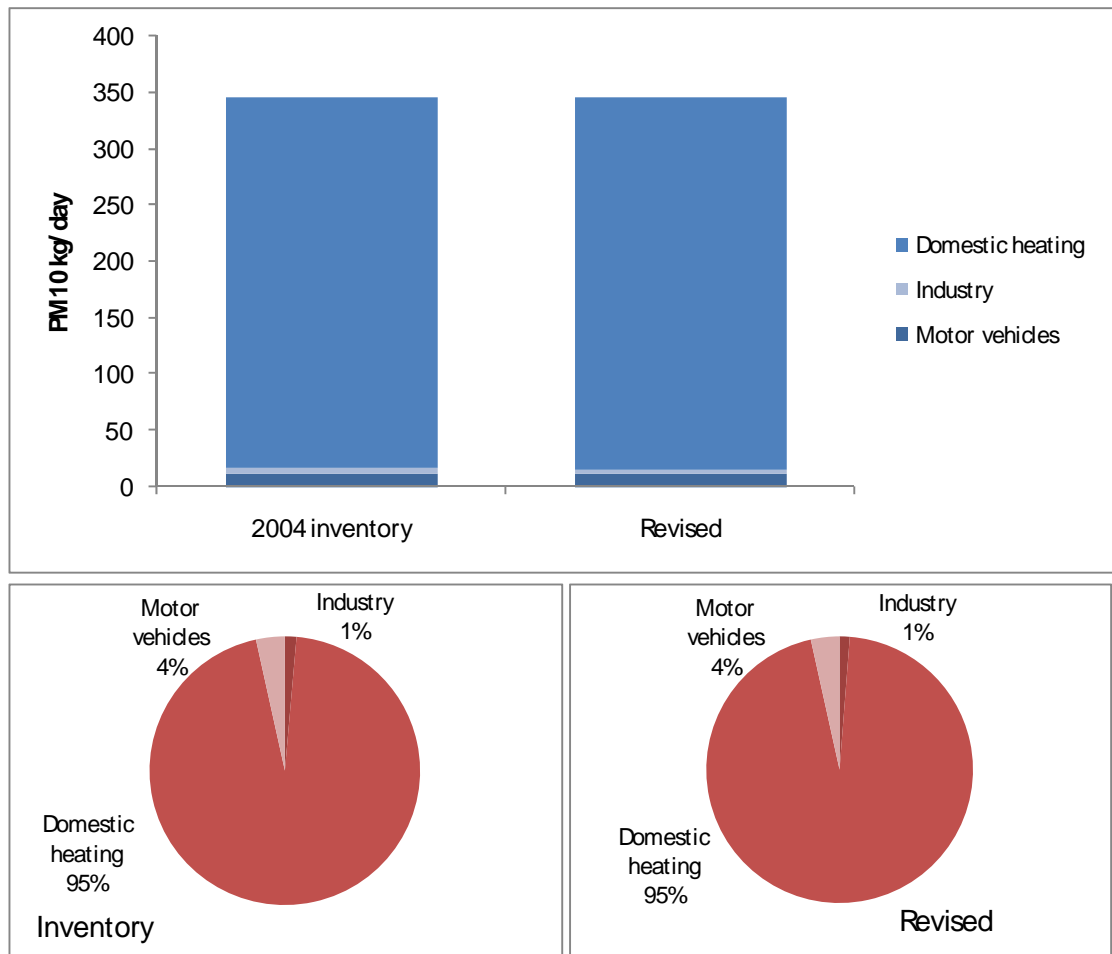

Figure 3.1: Comparison of revised 2006 baseline emissions to 2004 inventory assessment

The only scheduled change indicated from the survey was the addition of a wood fired boiler at the existing wood products industry in Kaiapoi. The boiler profile for 2013 is based on the 2006 profile with the addition of a “new” wood fired boiler.

Figure 3.2 compares industrial and commercial PM₁₀ emissions from combustion activities in Kaiapoi by source for 2006 and 2013.

The estimated change in emissions from 2006 to 2013 is 2.3 kilograms per day for combustion emissions. This equates to an increase of 55% of the 2006 emissions but does not significantly increase the industrial contribution (increase from approximately 1% to 2% of total PM₁₀ emissions from all sources).

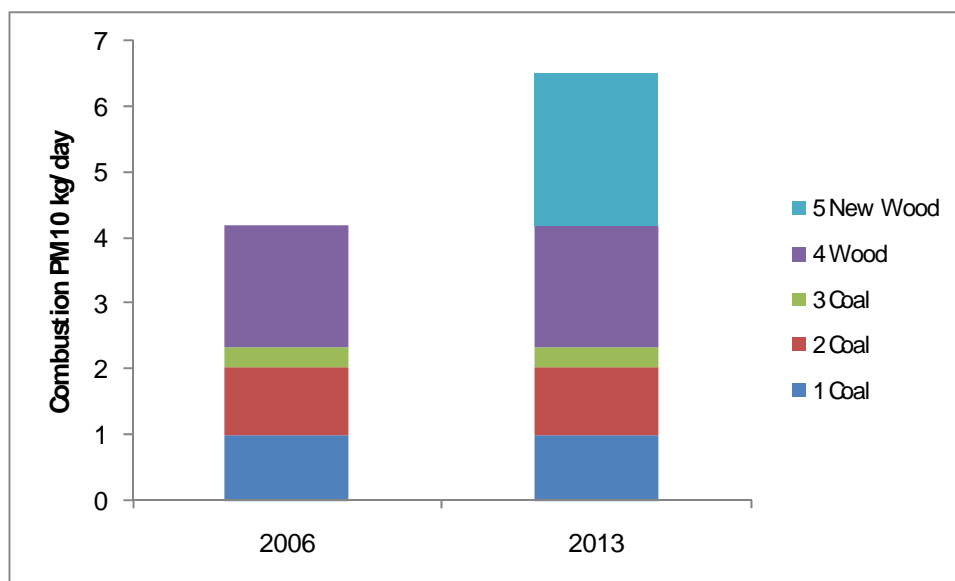

Figure 3.2: Industrial combustion PM₁₀ emissions by source – 2006 and 2013⁴

4 Least cost options for meeting the emission limits

In general, industrial and commercial boilers in Kaiapoi with existing emission limits greater than 50 mg/m³ fall within two general boiler classifications. Information on boiler technology and reducing boiler emissions are outlined in appendices F and G of the report. These include coal boilers less than 1MW and wood fired boilers. Diesel and LPG boilers are not included because emissions are unlikely to exceed 50 mg/m³ (Appendix B).

Appendix F discusses the main combinations of boiler and fuel burning equipment to be found in Canterbury. It is by no means exhaustive as there are an enormous number of ways (and variations on ways), of burning fuel in a boiler. The essence of Appendix F is that there is a wide variety of boiler equipment of widely differing ages, installed in different ways in different locations, all working under a range of different operating regimes.

Effective and economic emission control of the relatively small solid fuel-fired boilers that are typical across Canterbury is not easy. To quote from the International Energy Agency, an industry organisation funded by governments to promote the sustainable use of coal, *“Such boilers (stoker, chain grate, spreader stoker and the like) are commonly used in sizes equivalent to 10-25 MW, but emissions control tends to be uneconomic from such units, apart from the use of cyclones for particulates removal. Combustion is relatively unstable, so that there can be intermittent emissions of CO, NOx and organics”*.

A similar quote from a 2006 report by the Finnish Funding Agency for Technology (TEKES) states that:

“Overall, the FINE programme confirms that there is a clear window of opportunity for innovation in combating particulate emissions in energy generation and industry...”

This is particularly clear in respect of small plants rated below 10MW for which no cost-efficient fine particulate control technology exists as yet - something that is highlighted by the

⁴ Boilers were numbered by fuel type to remove the identification of industry but allow for a comparison of emissions by source

fact that fine particulate emissions from larger energy generating facilities are low compared with those from small scale wood combustion."

Nonetheless, we have chosen conversion and abatement strategies that are available and technically possible to achieve the various PM₁₀ limits specified in the report.

In order to simplify the situation for the purposes of this report, four different outputs with boilers of particular types were chosen as being representative of a significant proportion of the Canterbury boiler fleet. Costs were obtained for taking each typical boiler in an "average" location and assuming an "average" degree of difficulty for a conversion to another fuel (in some cases) or for the addition of emission abatement equipment.

Table 4.1 shows the Least Cost Options (LCO) for each emission limit and summary emissions information (mg/m³). While all measures are estimated to have an economic lifetime of 30 years, any that involve "add-ons" (as distinct from fuel conversions) will require significant maintenance and replacement of some elements within that time. The actual lifetime of the boiler plus the abatement equipment will depend primarily on the remaining useful life of the boiler. Most of the boilers in Kaiapoi are nearing the end of their likely economic lives.

The costs that we have shown assume average costs of fuel conversion or emission control equipment. It must be clearly understood that in many individual cases the actual conversion / abatement costs may be very different. Indeed, with some equipment conversion or abatement installations may be impossible. In those cases, complete new boiler installations would be required. In the absence of carrying out detailed technical assessments of a least a significant proportion of the boiler fleet, there is no way of estimating the number of boiler installations that would incur significantly higher conversion / abatement costs, nor those for which it is an impossibility. For the purposes of this report we have assumed that all boilers in all locations are convertible.

There are no "one-size-fits-all-off-the-shelf" conversion / abatement solutions. Each installation must be designed and built specifically for that location and application.

The analysis of least cost options for each emission limit is based on the consent compliance and enforcement regime existing at the time of writing. The status quo regime enforced by Environment Canterbury requires occasional testing (typically once per year) of the particulate matter emission concentration from large solid fuel-fired boilers. Testing is undertaken according to standard methods involving three isokinetic samples. The results for each of the three samples are averaged to give an emission concentration that is compared to the authorised limit for compliance purposes. Existing resource consents typically require emission testing to occur when boilers are operated at greater than 50% of capacity. Such testing requirements are imposed by the NRRP: Air Chapter for solid fuel-fired boilers larger than 1MW in the Christchurch Clean Air Zones.

Under the current regime, emission testing is normally arranged by the boiler operator and undertaken by an independent consultant. Therefore the tested boiler is usually well operated at steady state at the time of testing. If the test fails the compliance limit, some operators may choose to tune the boiler, change coal supply and make other necessary adjustments before re-testing to attempt to achieve compliance. These status quo testing requirements are not onerous. It is important to recognise that the nature of the current testing regime is such that the operator has control over test conditions and compliance can normally be achieved if the control technology is capable of achieving at some point in its operating envelope PM concentrations in the order of the emission limit.

This has very important implications for the selection of least cost options in this report, especially in relation to the 250mg/m³ PM limit. This emission concentration is at the limit of what can be achieved by modern cyclone technology for solid fuel-fired boilers that are well operated and maintained, particularly in the case of coal-fired drop tube (e.g. Vekos), spreader and low-ram stoker boilers. Under the current testing regime it is technically

possible for these boilers to be fitted with two well-designed multi-cyclone units and operated at a steady rate to demonstrate compliance with the 250mg/m³ PM limit. However normal operating conditions of varying load and firing are likely to produce different results. If a stricter approval and testing regime came into force which required the 250mg/m³ limit to be met under all reasonable operating conditions, and which included more frequent and random tests, it is probable that many Vekos boilers fitted with multi-cyclones (in addition to the standard internal cyclone) would be found to not comply with the 250mg/m³ limit. Because of the significant uncertainty associated with this limit for both boiler operators and control equipment suppliers, it must be recognised that some operators would have to fit bag filters in order to achieve a 250mg/m³ limit with certainty.

The effectiveness of the status quo emission testing requirements would be improved by requiring well-documented operation and maintenance procedures and records to be kept as part of resource consent requirements. Including a component of random testing by independent contractors (at least for the larger boilers) would also help to ensure that actual emissions during normal operation do not significantly exceed tested PM emissions. The authors consider that these measures would result in a significant improvement in real PM emissions. If a tighter compliance monitoring regime comes into force in future, it is probable that the costs of meeting the 250mg/m³ limit for some drop tube, spreader and low-ram stoker boilers have been underestimated in this report. However the selection of bag filters for some of these boilers (at greater cost) would also result in a significant reduction in PM emissions to approximately 50mg/m³.

Table 4.1: Least cost options (LCO) for meeting emission limits

Classification	TSP mg/m ³	Emission rate PM ₁₀ (g/kg)	LCO 300 mg/m ³ TSP	Emissions 300 mg/m ³ TSP	LCO 250 mg/m ³ TSP	Emissions 250 mg/m ³ TSP	LCO 150 mg/m ³ TSP	Emissions 150 mg/m ³ TSP	LCO 50 mg/m ³ TSP	Emissions 50 mg/m ³ TSP
Coal Underfeed	300	2.0	Nothing	300	Fuel switch pellets	120	Fuel switch pellets	120	Fuel switch diesel	21
Wood Vekos	280	1.6	Nothing	280	Two multiclones	250	Bagfilter	50	Bagfilter	50

1. Although we have shown bag filtration to be the chosen least cost option for reducing emissions from shell and tube boilers firing wood, this is not entirely clear. At the time of writing, we are aware that this option has been successfully achieved at one site in the past but are unaware of any such installations that are in actual current operation. There are some serious technical considerations relating to the carry over of hot embers into the baghouse that need to be satisfactorily addressed. The alternatives are either ceramic filters or a change of fuel to LFO. Note also the quotations in Appendix G.

5 Reductions in emissions

In the absence of additional controls on growth in PM₁₀ from industrial and commercial activities in Kaiapoi daily PM₁₀ emissions are estimated to increase by 55% from 2006 to 2013.

One management scenario not considered in this report is not allowing future increases in PM₁₀ emissions or imposing stricter emission limit requirements for new industry in Kaiapoi. Not allowing future increases in PM₁₀ is estimated to achieve a reduction of around 2.3 kilograms of PM₁₀ per day. However, there is clearly a significant amount of uncertainty in the estimated effectiveness of imposing stricter limits on new industries because of the difficulties in predicting future industry.

Figure 5.1 shows the estimated daily PM₁₀ emissions for the baseline scenario and the different policy options, assuming implementation in 2012.

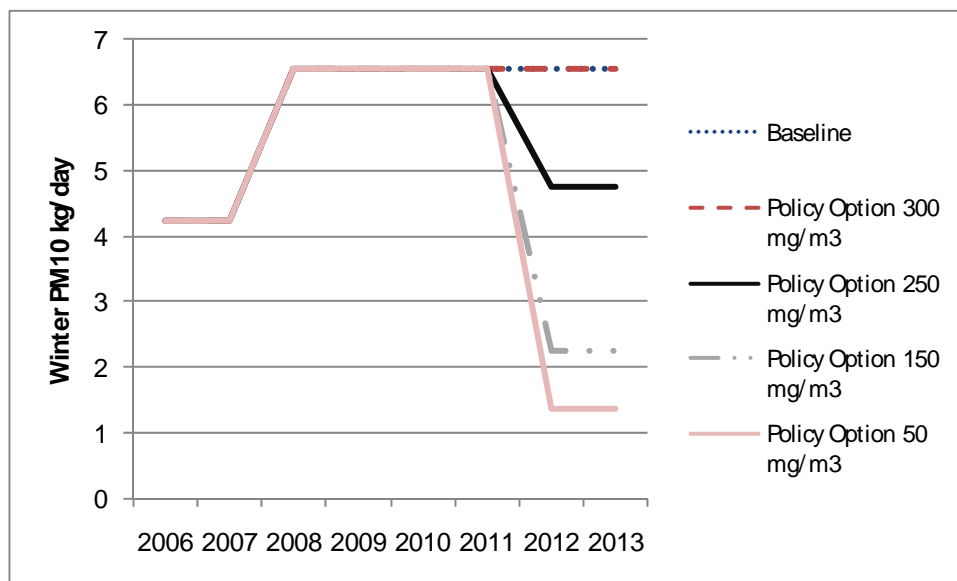

Figure 5.1: Daily PM₁₀ from coal-fired boilers in Kaiapoi from 2006 to 2013

The existing boilers are all likely to meet the 300 mg/m³ TSP emission limit. A 27% reduction in emissions is estimated for the emission limit of 250 mg/m³ and a 66% for the 150 mg/m³ limit (Figure 5.2). The additional reduction associated with an emission limit of 50 mg/m³ is around 13% and is associated with fuel switching to diesel for the underfeed stokers (Table 5.1).

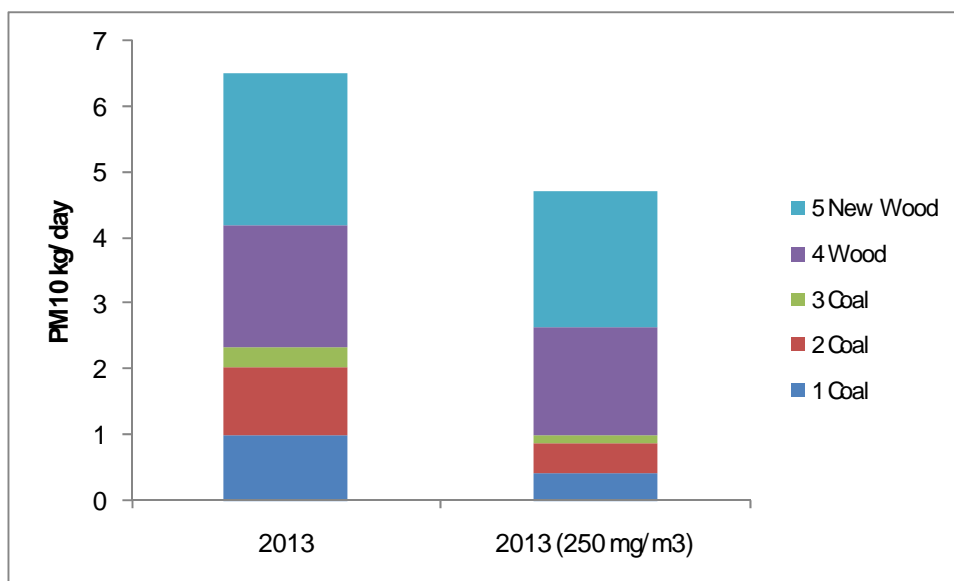

Figure 5.2: Baseline and policy option 2 (250 mg/m³) 2013 combustion PM₁₀ emissions by individual boiler⁵

Table 5.1: Reductions in PM₁₀ emissions

	2006 emission (kg/day)	2013 emission (kg/day)	Change from baseline at 2013 kg/day (winter)	Percent reduction at 2013	Percent of 2006 emissions
Baseline	4	7	0	0%	155%
Policy option 300 mg/m ³	4	7	0	0%	155%
Policy option 250 mg/m ³	4	5	2	27%	112%
Policy option 150 mg/m ³	4	2	4	66%	53%
Policy option 50 mg/m ³	4	1	5	79%	33%

6 Cost effectiveness

Table 6.1 compares the costs and benefits of implementing the policy options for Kaiapoi. The costs associated with these LCOs were estimated based on the cost data detailed in Appendix C.

The option of setting an emission limit of 300 mg/m³ is not estimated to result in any reductions in PM₁₀ emissions or associated capital or operating costs. The costs shown for this option in Table 6.1 reflect the compliance costs that would be required for industry to demonstrate that they meet the emission limits.

Of the options considered, the most cost effective policy option for reducing PM₁₀ from industrial and commercial activities in Kaiapoi is setting an emission limit of 250 mg/m³. This gives a total cost of around \$114,000 (NPV for 2006 based on 6% discount rate) and a cost of around \$63,000 per kilogram of PM₁₀ reduced. The magnitude of the reduction is small at four kilograms of PM₁₀ per day.

An alternative to setting an emission limit for existing boilers would be setting an emission limit for new boilers in Kaiapoi of 250 or 150 mg/m³. This is likely to be a cost effective method of reducing potential future PM₁₀ emissions. As in many other situations it is usually cheaper to install entirely new plant to a higher standard in the first place than to attempt to retrofit existing installations.

⁵ Boilers were numbered by fuel type to remove the identification of industry but allow for a comparison of emissions by source

The analysis is most sensitive to variations in emission factors for both the baseline emission rates and the impact of technology in reducing emissions. As discussed in Appendix B, there are uncertainties with the emission factors for both baseline scenarios and control options. Even in the absence of these uncertainties, results should be treated as indicative only, particularly in areas where there are only a limited number of boilers, because of the potential for site to site variability in emissions and the costs of implementing control options.

In Kaiapoi, the emission rate for wood fired vekos boilers has a reasonable impact on the estimated PM₁₀ reductions. The analysis is not sensitive to changes in assumed interest rate as the relative effectiveness of different policies remains unchanged with variations to this variable. Total estimated costs decrease by around 10% if the discount rate is increased from 6% to 8%, however.

Table 6.1: Cost effectiveness of policy options - all boilers

	Total cost	Reduction in PM ₁₀ (kg/day) winter	Cost \$ per kg reduction in PM ₁₀
Policy 300 mg/m ³	\$ 3,990	-	
Policy 250 mg/m ³	\$ 113,642	2	\$ 63,220
Policy 150 mg/m ³	\$ 339,229	4	\$ 78,713
Policy 50 mg/m ³	\$ 337,069	5	\$ 65,110

7 Conclusion

Of the four policy options examined, the most cost effective is an emission limit (TSP) of 250 mg/m³. This is estimated to reduce PM₁₀ emissions during the winter by around 2 kilograms per day and cost around \$114,000 (NPV for 2006 at 6% discount). This gives an estimated cost of \$63,000 per kilogram of PM₁₀ reduced.

Although these conclusions are valid at this time, it must not be forgotten that the technology of emissions control is moving continuously. Within the next 12 months it can be reasonably expected that wood gasification systems will be economically available in New Zealand, and ceramic filter houses may have come down significantly in cost. These changes could have a dramatic impact on available emission reduction options.

Another factor influencing the effectiveness of the emission reduction options is the enforcement approach adopted by Environment Canterbury. The analysis of least cost options for each emission limit is based on the consent compliance and enforcement regime existing at the time of writing. The status quo regime enforced by Environment Canterbury requires occasional testing (typically once per year) of the particulate matter emission concentration from large solid fuel-fired boilers. The main policy option influenced by the assumption of the status quo with respect to enforcement is the 250 mg/m³ limit as the LCO selected for this option for a range of coal and wood-fired boilers (the two multiclone system) may not be adequate if a more stringent compliance testing regime were adopted. Another benefit of a more stringent compliance monitoring and enforcement approach is the potential for improved emissions if industry are motivated (for example, through the implementation of random emissions testing) to carry out good practice boiler operation continually.

Appendix G details the potential improvements in efficiency that can occur as a result of careful operation, good maintenance, and simple control improvements to systems, without making any fuel conversions, additions, or modifications. This indicates that these measures may be capable of reducing emissions by perhaps as much as 30%. They can be achieved without undue technical difficulty simply by reducing the amount of fuel burned; a win-win to the environment and operator alike.

8 Acknowledgements

The assistance the following in providing information and making available data was greatly appreciated.

- Desmond Gong and Duncan Mackenzie, Solid Energy, Christchurch.
- Geoff Paynter, Eric Collins and Doug Pigou, Taymac Engineering, Christchurch.
- Nigel Black, Glosfume Ltd, Cheltenham, Gloucester, England
- Gavin Headley, Alternative Energy Solutions Ltd, Pukekohe
- David Gibson, Scotts Engineering Ltd.

References

Coal Research Limited, 2005, Review of particulate emissions from industrial coal combustion in New Zealand. CRL Energy Report 05-11025.

Iseli, J. 1999, Technical Information Required to Establish the Economic Costs of Industrial Fuel Burning Rules in the Draft Air Plan for Christchurch. Unpublished technical report prepared for Environment Canterbury by Specialist Environmental Services Ltd.

Keer-Keer & Bourke, et al, 2006, Central New Brighton School, Emission Assessment of Boiler, September 2006, K2 Environmental Ltd

Kingett Mitchell Limited, 2006, Forecast of PM₁₀ emissions from industrial and commercial activities in Canterbury. Report prepared for Environment Canterbury.

Lee, I He, T Herage, B Young, V Razbin, E Kelly and R Pomalis, 2002, Fuel Effects on Particulate Emissions from Fuel Oil Combustion Systems Under Accelerated Laboratory Conditions, SW, CANMET Energy Technology Centre, Ottawa, Canada.

M Ohlström, J Jokiniemi, J Hokkinien, P Makkonen, and J Tissari., 2006, Combating Particulate Emissions in Energy Generation and Industry. Edited by P Herring, published by VTT Technical Research Centre of Finland, ISBN 952-457-246-X.

McCauley, M., and Scott, A., 2006. Inventory of emission to air in Waimate, Ashburton, Kaiapoi and Rangiora, 2004. Report R06/24, Environment Canterbury.

Scott, A., and McCauley, M, 2007. Meeting the National Environmental Standards for PM₁₀ in Kaiapoi and Kaiapoi. Environment Canterbury – in preparation.

Ministry for the Environment, 2005, Updated Users Guide to Resource Management Regulations 2004 <http://www.mfe.govt.nz/publications/rma/user-guide-draft-oct05/html/page1.html>

Opus International Consultants Limited, 1998. Particulate Testing of Coal Boilers, Physical Testing of 16 School Boilerhouses Winter 1998 - Ministry of Education. Further information provided to Environment Canterbury in support of air discharge permit applications for school coal boilers in Christchurch. October 1998

USEPA AP42, 2001, Emissions Database <http://www.epa.gov/ttn/chief/ap42/>

Appendix A: Industrial Emission Survey Form

Company Name _____

Person completing Questionnaire _____

Email address: _____ Phone No. _____

Q1. Nature of business: _____
(e.g., textile manufacture, fertiliser production)

Q2. Please tick box for each type of boiler you operate and indicate how many of each you have:

Discharge Type: Number of boilers

Coal boiler Number:

Diesel boiler Number:.....

LPG boiler Number:.....

LFO boiler Number:.....

Wood burner Number:.....

Waste oil burner Number:.....

Other - specify Number:

Q3: What is the primary purpose of the boiler plant:

Q3. For each boiler please fill in the following information:

Discharge type e.g., coal boiler 1	Output (kW, kg steam/hr)	Boiler Maker e.g., Anderson	Approximate year of boiler manufacture	Burner make	Burner output (e.g., kW, btu/hr)	Approx year of burner manufacture	Any particulate control measures in place? (eg venturi cyclones, bagfilters)	Fuel Type and grade e.g., light distillate oil	Annual Quantity of Fuel used (approx) e.g., 500 tonnes/year
1.									
2.									
3.									
4.									

Q4: During the winter months, how many days per week do you use the boiler/ boilers _____

Q5. Seasonal variation:

If the annual fuel use quantity indicated in **Q3** varies throughout the year, please indicate the percentage of the total that occurs in each of the four periods below e.g. *Sept-Nov 10%, Dec-Feb 10%, Mar-May 30%, Jun-Aug 50%*

Discharge type	Sept - Nov	Dec-Feb	Mar-May	Jun-Aug
1.				
2.				
3.				
4.				

Q6. Scheduled changes between 2007 and 2013:

6a: Do you have any major refurbishment/upgrade plans before 2013?

If yes please describe: _____

6b: Do you have any major replacement plans before 2013? _____

If yes please describe: _____

6c: Do you have any major fuel switching plans before 2013? _____

If yes please describe: _____

6d: Are you considering alternatives to boilers? _____

If yes please describe: _____

Thank you for completing this survey. If you have any questions please call
03 9825966

Appendix B: Emission Rates for Industrial Boilers

Emission rates for industrial boilers were determined based on an evaluation of local emissions data and a comparison of these to the USEPA emission factors. The latter include TSP and PM₁₀ emissions for a range of boilers. In New Zealand measurements are primarily available for TSP but limited data are available for PM₁₀.

The US EPA data is graded for reliability A to E, A being top class data from an adequate number of randomly chosen sites with sampling carried out via a sound methodology. The opposite extreme is E, where there are many uncertainties surrounding the methodology and validity of the data, or there is evidence of variability within the source category. Generally A, B, and C category data can be considered as being of average or above average quality. D and E are only used in the absence of anything better. In the following table, there are two grades shown. The first refers to the quality of data relating to filterable particulates, and the second to the data which estimates the PM₁₀ emissions.

It should be noted that there are a number of geometries of plant for which there exists New Zealand data but for which there is no EPA data. The EPA data surrounding underfeed stokers, (both with or without cyclones) is rated "D". It is in the category of underfeed stokers that we expect the majority of smaller Canterbury coal fired boilers. CRL (2005) includes several measurements on underfeed stoker boilers in New Zealand.

Looking at the data from all sources, it is clear that boilers fired on light distillate oil (diesel) or LPG have typical emission levels that are low, well below the lowest emission classification that ECan have required this study to consider. Accordingly, emission control methods for boilers, air heaters or like devices that use LPG or diesel were not included in the cost effectiveness evaluation.

The devices that are left therefore are those fired on coal, wood or light fuel oil, (residual fuel oil).

It is notable for those solid fuel devices for which there exists comparable EPA and NZ data, that the NZ data records emission rates of typically one third to one half of the EPA data.

There are four results in the following table which are shaded. The data comes from two contracts carried out by Powell Fenwick Consultants one of which involved the addition of cyclones and a bag house to a drop tube (Vekos) pattern boiler, and the other of which related to the conversion of a vertical tube under fired stoker boiler from coal to wood pellets. In both cases the data are reliable, the necessary testing having been carried out by recognised testing organisations to appropriate standards, but relate only to single installations.

The results for the drop tube (Vekos) boiler before conversion are lower than the average test results obtained by CRL (Coal Research Limited), being 525mg/m³ against 707mg/m³ and 802mg/m³. Most Vekos boilers tested have a small integral cyclonic grit arrestor as a part of the standard design. Addition of multi cyclones further reduces particulate matter emissions.

The "before" results for the coal conversion of an underfeed stoker to wood pellets, while running on coal, are less than 35% of those suggested by the US EPA. Testing of 16 coal-fired underfeed stoker boilers at schools in Christchurch was undertaken by ESR in 1998 (Iseli, 1999). This emission testing found that the majority of boilers had corrected emissions of less than 250mg/m³ TSP, with only three of the tested boilers having emissions greater than 300mg/m³ at the time of measurement. (Note: These results are not tabulated in Table A1).

There is other unquantified anecdotal evidence from workers in this area that they have found New Zealand PM emissions for coal to be significantly less than the EPA data, typically by a factor of two or more.

The emissions from burning light fuel oil (LFO) are relatively high (around 100 mg/m³) based on USEPA guidelines. Given that the EPA data is grade A, and that oil is a closely controlled internationally traded commodity, there is no reason to suppose that NZ emissions from burning LFO in correctly operated boilers are significantly different to those recorded in the USA.

LFO supplied in New Zealand has a nominal maximum sulphur content of 2% by weight. The particulate emissions of oil fuels are proportional to the sulphur content. If New Zealand could be supplied with say a 0.5% LFO, (which is technically possible, although the economics are unknown), then the particulate emissions would fall to something less than 50mg/m³. (Note there is a dearth of data concerning this for LFO specifically, but it is known that the particulate emissions of both diesel and heavy fuel oils are a linear function of sulphur content. There is no reason to suppose that light fuel oil will behave any differently given that it is a mix of diesel and heavy oil).

In the absence of a reduction in the supplied sulphur content of the LFO, the alternatives are much the same as coal; a change of fuel to light distillate (diesel), tallow, vegetable oil or the addition of filtration.

Test data for three boilers burning wood waste in New Zealand are provided in Table A1. One data set is for burning wood waste in a shell and tube boiler with drop tube stoker (Vekos), giving results for combustion of dry shavings and wet sawdust that has been "flash dried" by combustion gases from the boiler. The other two test results are for underfeed stoker wood-fired boilers. In the case of underfeed stokers, performance on wood waste does not appear to be significantly different to that on coal. There are a number of reasons for this, but in the absence of detailed knowledge of the fuel, firing condition, and the state of the boilers, it can only be speculation. However for Vekos boilers, particulate matter emissions burning wood are typically lower than emissions from burning coal.

Table A2 lists the typical emissions for boilers in Canterbury that are well operated without any additional post combustion treatment. They represent the current starting point. This list is not exhaustive as there are too many possible variations of plant and equipment to list. It is however reasonably indicative of the main types of plant and equipment in current operation.

Looking across all of the coal emission data it is very clear that there is considerable variation. It must be stressed that for intelligent decisions to be made on the most appropriate abatement measures, proper on-site particulate measurements are needed. In the smaller boiler sizes it may not be necessary to survey every boiler, but in larger industrial boilers it is. Such boilers are generally custom made to particular requirements and as such apparently similar boilers can have very different particulate performances based on firing rates, combustion chamber geometries and velocities, flue arrangements, fuel choice, operating practices and the like. It may well be that the actual emission rates for some sites are considerably different to those that we have assumed for the purposes of this study.

There are some options that have not been fully explored because they are too new. Long before 2013 they can be expected to either be fully proven and available, or shown to be inappropriate. Waste cooking oils, ceramic filters and gasifiers fall into this category. Significant progress in these areas can significantly assist in emission reductions. Animal oils (tallow) are in use now with particulate emissions similar to diesel oil.

Work will be carried out by Solid Energy later on this year to determine the suitability of drop tube stoker (Vekos) pattern boilers for firing wood pellets. If the tests prove successful, then another alternative will be available to bag houses for a significant number of boilers.

The wood pellet emission data presented in Table A1 is given as 120mg/m³. This is consistent with peak test results and 5mg/m³ less than the value for which resource consents have been granted for two Canterbury schools. However during the tests that generated the data, it became apparent that with good control, emission levels of less than 100mg/m³ might be reasonably achievable. It is important that further work be undertaken to monitor those wood pellet conversions that have, (or will have in the future), taken place to confirm or otherwise the achievability of lower emission levels.

Table A3 outlines the emission factors used to estimate the impact of the different policy options. For the reasons outlined above these were based primarily on the New Zealand specific test data where applicable. The proportion of the PM₁₀ size fraction in TSP is based on CRL New Zealand data (CRL, 2005) for coal-fired boilers and USEPA data for wood-fired boilers. Particulate matter emissions from oil and gas-fired boilers and boilers fitted with bag filtration are assumed to be 100% PM₁₀. The latter assumptions were adopted in the absence of quality information in order to provide a conservative estimate of emissions. Some USEPA AP42 data were available for oil burning but this was not considered to be of adequate quality and, based on knowledge of combustion processes, many of the results for PM₁₀ seem unusually low. In both cases (oil and bag filtration), the assumptions have negligible impact on the analysis.

For this assessment the following PM₁₀/PM ratios were assumed:

- Vekos boiler with internal cyclone only – 61% PM₁₀
- Vekos and spreader stoker with additional multi cyclone – 70%
- Chain grate boiler and low ram stoker – 70%
- Wood-fired boiler – 90%
- Underfeed stoker – 70%
- Bag filtration – 100%
- Oils – 100%
- LPG – 100%

Table A1: Summary of emission data available

	CRL			USEPA AP42						Grade: The first grade refers to the quality of the TSP data, the second to the PM ₁₀ data
	TSP ¹ kg/tonne coal	mg/m ³ TSP	Standard deviation/ average	lbs/ton TSP	kg/tonne TSP	mg/m ³ TSP	lbs/ton PM ₁₀	kg/tonne PM ₁₀	mg/m ³ PM ₁₀	
Hand fed boilers				15	7.5	791	6.2	3.1	338	Grade "E/E" data
Chain grate + multicyclone	2.1	222	40%	9	4.5	475	5	2.5	272	Original unit lbs/ton. Grade "C/E" data
Chain grate + bag filter	0.7	74	6%							
<i>Chain grate pre-2002</i>	1.3	137	47%							
Spreader + multicyclone	3.8	401	44%	17	8.5	897	12.4	6.2	675	Assumes re-injection. Original unit lbs/ton. Grade "B/E" data.
Spreader + multicyclone (without flyash re-injection)				12	6	653	7.8	3.9	411	From table 1.1-9, page 1.1-29 EPA-AP42
Spreader + multicyclone (with flyash re-injection)				17	8.5	897	12	6.0	633	From table 1.1-9, page 1.1-29 EPA-AP42
Spreader + bag filter	1.8	190	49%	0.48	0.24	25	0.072	0.04	4	From table 1.1-9, page 1.1-29 EPA-AP42
Spreader + ESP	0.14	15	33%	0.12	0.06	6	0.44	0.22	23	From table 1.1-9, page 1.1-29 EPA-AP42
<i>Spreader pre-2002</i>	2.1	222	35%	66	33.00	3418	13.2	6.6	719	Original unit lbs/ton. Grade "B/E" data
Low ram stoker + multicyclone	3	316	41%							
Vekos + internal cyclone	6.7	707	21%							
<i>Vekos pre-2002</i>	7.6	802	35%							
Overfeed stoker				16	8	844	6	3.0	316	From Table 1.1-10, page 1.130, EPA-AP42
Overfeed stoker with multiple cyclones				9	4.5	475	5	2.5	264	From Table 1.1-10, page 1.130, EPA-AP42
Underfeed				15	7.5	791	6.2	3.1	338	Original unit lbs/ton. Grade "D/E" data
Underfeed + multicyclone	1.9	200	25%	11	5.5	580	6.2	3.1	338	Original unit lbs/ton. Grade "D/E" data
Vekos		525								Note. This is a pair of results

Vekos + multicyclone + bag filters		55								for one boiler, before and after the addition of cyclones and bag filters.
Underfeed (coal)		280		15	7.5	791				Note. This is a pair of results for one boiler, before and after a conversion to operate on wood pellets. EPA data has reliability rating of "C".
Underfeed (wood pellets)	0.91	120								
Vekos boiler on wood chips/waste		266, 359								Results for one boiler. 266mg/m3 for dry shavings, 359mg/m3 burning 'flash dried' wet sawdust.
Underfeed stoker, wood .		192, 281								192mg/m3 for coil boiler burning wood chips, 1 test. 281mg/m3 for underfeed stoker burning wood waste, 1 test.
				lb/ tonne						
Dry wood				4	2.0					Taken as a reasonably representative value across a range of possibilities.
				lbs/1000U SG						
No. 5 Oil (LFO)				10	1.3	97	10	1.3	97	
No. 5 Oil (LFO) with multiple cyclone							2	0.26	21	Table 1.3-5 page 1.3-16, EPA-AP42
Distillate (lbs/1000gallons (US))				2	0.28	21	2	.28	21	
LPG (typical)				0.44	0.099	7.72	0.44	.099	7.72	

¹ Emission rates in kg/tonne coal burned have been converted to mg/m³ based on burning of typical coal used in boilers in Canterbury (approximately 22MJ/kg gross calorific value). For wood-fired boilers, the conversion is based on burning relatively dry wood (approximately 20% moisture, 16MJ/kg gross calorific value).

Table A2: Boiler Types / Typical Total Particulate Emission Rates (mg/m³ corrected to standard conditions) without modification and good maintenance / operating practice.

Boiler Construction	Coal					Wood	Oil		Gas (LPG)
	Underfeed stoker (no controls or single cyclone)	Underfeed stoker with multi-cyclone	Drop Tube Stoker (Vekos with internal cyclone)	Chain Grate Stoker with multi-cyclone	Low Ram, Spreader and Vekos with multi-cyclone		LFO	Light (Diesel)	All types
Sectional	300 (1)	200 (4)				280 (5)	100mg/m ³ all types	21 mg/m ³ , all types	8mg/m ³ , all types
Shell & tube, multi-pass			650 (2)	220 (4)		280 (6)			
Shell & tube, reverse pass									
Vertical shell & tube	280 (3)	200 (4)							
Water tube				220 (4)	300 (7)				
Waste heat									
Tubular gas									
Condensing									

- (1) Data comes from ESR 1998 testing of 16 school boilers in Christchurch, average <math><300\text{mg/m}^3</math>, with only 3 tests above this value
- (2) Data comes from Powell – Fenwick project work, CRL (2005) + other known NZ emission test results (average of 13)
- (3) Data comes from Powell-Fenwick project work.
- (4) Data from CRL (2005), plus knowledge of other NZ testing.
- (5) From USEPA data at 1.8g/kg, assuming typical 16MJ/kg wood burned. Consistent also with testing
- (6) Based on limited NZ test data and USEPA data.
- (7) Based on information provided by suppliers and limited emission test data, assuming good operation at steady rate at the time of testing. Refer to the discussion in Section 6.

Table A3: PM₁₀ emission factors (kg/tonne) for least cost options (LCO) for meeting emission limits

Classification	Baseline Emission rate kg/tonne PM ₁₀	LCO method	Emissions Factor kg/tonne (300mg /m3 TSP)	LCO method	Emissions Factor kg/tonne (250mg /m3 TSP)	LCO method	Emissions Factor kg/tonne (150mg /m3 TSP)	LCO method	Emissions Factor kg/tonne (50mg /m3 TSP)
Coal underfeed	2.0	Nothing	2.0	Fuel switch pellets	0.8	Fuel switch pellets	0.8	Fuel switch diesel	0.3
Wood Vekos	1.6	Nothing	1.6	Two multiclones	1.4	Bagfilter	0.5	Bagfilter	0.5

Appendix C: Cost data

The costs to industry if Environment Canterbury were to set an emission limit for industrial activities include:

1. Capital costs.
2. Operating costs.
3. Compliance costs.

Table A4 outlines the capital and operating costs associated with different fuel and boilers. Costs have been gathered for four representative boiler sizes.

- 200kW represents the smallest boilers in the fleet, typical of say a primary school, an older small office block or the like.
- 1MW represents the larger end of the underfeed stoker fleet, typical of say a large high school or medium sized institution.
- 1.8MW is a shell and tube boiler such as might be found in a hospital, training college, smaller industrial installation or the like.
- 4.5MW is a 10,000lb/hr shell and tube boiler, a very common size in the industrial boiler fleet.
- Table A4: Costs of boiler technology and fuel

	200kW		1MW		1.8MW		4.5MW	
	Capital Cost	Fuel Cost c/kWh	Capital Cost	Fuel Cost c/kWh	Capital Cost	Fuel Cost c/kWh	Capital Cost	Fuel Cost c/kWh
Coal Boilers unaltered		4.0		3.9		3.81		3.81
LFO Boilers unaltered						9.2		9.2
Coal to diesel	\$25,000	12.7	\$30,000	12.2	\$63,000	12.2	\$114,000	12.2
Coal to LPG	\$25,000	14.6	\$31,000	14.0				
Coal to Wood Pellets	\$6,000	9.4	\$6000	9.1				
Coal to Light Fuel Oil					\$71,000		\$128,000	
Addition of a grit arrestor cyclone	\$18,000	4.0	\$28,000	3.9	\$38,000	3.81	\$48,000	3.81
Addition of a grit arrestor & grit re-firing system		4.0		3.9	\$50,000	3.81	\$60,000	3.81
As above plus a bag filter	\$100,000	4.0	\$150,000	3.9	\$220,000	3.81	\$300,000	3.81
Addition of two multi cyclones		4.0	\$60,00	3.9	\$67,000	3.81	\$75,000	3.81
Addition of a cyclone plus a ceramic filter	\$120,000	4.0	\$180,000	3.9	\$260,000	3.81	\$360,000	3.81

Notes:

1. The fuel cost/kWh is based on the following fuel costs, calorific values, and assumptions of boiler efficiency. It represents the cost per kWh of useful energy at the boiler outlet. The calorific value (CV) of coal will vary according to the source, but the number chosen is reasonably representative of the grades presently used in Canterbury. Likewise, boiler efficiencies will vary between installations, but are chosen to be representative of typical boilers in average operating condition.
 - Coal \$167 /tonne, 75% boiler efficiency, CV= 21MJ/kg (net)
 - LFO, \$0.82c/litre, 78% boiler efficiency, CV= 41MJ/l
 - Diesel, \$1.00/litre, 78% boiler efficiency, CV= 37.8MJ/l
 - LPG, \$1.40/kg, 84% boiler efficiency, CV= 49.51 MJ/kg

- Wood pellets, \$340/tonne, 76% boiler efficiency, CV= 19MJ/kg
2. Compliance costs include the cost to industry of demonstrating that they meet a particular emission limit. Costs have been estimated based on the assumption that emission testing would be required every two years after the date of implementation of the policy and that the cost of the testing is around \$1500 + GST per test. Compliance costs do not include an assessment of costs relating to the resource consent process should industry require consents as a result of the implementation of this policy.
 3. Permanent in-stack monitoring of obscuration is not currently a requirement for all industrial boilers in Canterbury, although it is a consent condition for a small number of large scale boilers. The capital cost of this equipment ranges from approximately \$10,000 to \$20,000. Obscuration meters do not measure particulate matter concentration directly, but they provide an indication of plume opacity and boiler operation. The costs associated with this equipment are not included in this analysis because the current use of obscuration meters is a requirement of the existing consent process individual consents and is not considered, at this stage, to be a requirement of the implementation of the policy options being considered here.
 4. No costs are shown for either wet scrubbers or electrostatic precipitators. Although technically feasible, both published sources and local suppliers advise that they are expensive to install and costly and trouble prone in operation at small sizes. (They are generally applied to very large electricity generation boilers). Accordingly, they were not priced.

Appendix D: Notes for implementation

Whatever technical solution is adopted to reducing the emissions from smaller solid fuel boilers (less than 1.5MW), it has to be simple, reliable and not require specialist operators or other specialist knowledge for normal operation and maintenance. Typically boilers of this size are installed in small institutions and small commercial operations. They are given an annual maintenance visit with perhaps daily visits by a caretaker for routine operations such as ash removal. Such institutions would be quite unable to support a complex solution.

For small boilers with underfeed stokers the best alternative at present is a conversion to wood pellets. It is believed that emissions of less than 100 mg/m³ can consistently be achieved with no more difficulty than is currently experienced with coal. Such a course of action also brings advantages in the form of reduced NO_x and SO_x emissions, and also shifts the users to a renewable carbon neutral source.

To assess the costs and benefits accurately for each site, each of the larger coal and wood fired installations should be visited individually to get accurate information on their existing equipment and to carry out particulate monitoring tests (particularly where testing has not occurred previously). There is significant variation in the available data (for good reasons) to make it unsafe to apply to an individual coal installation without first conducting site-specific measurements. This is not the case (to anything like the same extent) with oil or gas fuels as their increasing purity, conformity to standard, and ease of firing make them much more consistent with regards to particulate emissions.

Such wood pellet installations or conversions as have (or might) be undertaken should be monitored to get accurate data on levels of emissions that are reasonably achievable in ordinary service.

The importance of good operation and maintenance cannot be over stated. Larger operators are probably well aware of this; the sums of money involved make it incumbent upon them to be so. (though not necessarily when they are using a waste product as fuel that has a near zero cost). However, smaller operators, particularly in the commercial, educational sectors and the like are less likely to be aware of or concerned about energy efficiency (and by implication the quantity of emissions). A large problem in the commercial sector has always been that costs associated with boiler operations are relatively small in terms of the overall building operation and are passed on directly to tenants.

When a building or installation is significantly refurbished there is often minimal attention paid to the heating and air conditioning systems and their control or suitability for further use. Money spent in this area is often regarded as “dead”. A regulatory change that requires building owners to be able to demonstrate levels of energy efficiency and control for refurbished buildings that are at least reasonable (taking into account the basic age and design) would be beneficial.

Finally, this report should be updated regularly to improve its accuracy in the light of more current data, and to incorporate such technical developments as may have been made.

Appendix E: Summary Boiler Information

Boiler No.	Boiler type and fuel	Annual fuel consumption (tonnes)	Emissions kg/day PM ₁₀ winter 2006	Emission Factor g/kg PM ₁₀	Baseline Operating Costs 2006
1	Coal-fired boiler Underfeed with cyclones	42	1.0	2.0	\$ 7,014
2	Coal-fired boiler Underfeed with cyclones	42	1.0	2.0	\$ 7,014
3	Coal-fired boiler Underfeed with cyclones	17.5	0.3	2.0	\$ 2,923
4	Wood boiler/heater with cyclones	300	1.9	1.6	\$ 6,000

Appendix F: Boiler technology

This section outlines the various boiler and burner combinations that are in use in Canterbury and defines their typical particulate emission rates. It is important to note that these are typical rates and that there are a range of values (published or otherwise) upon which they are based. Emissions are a function of many things; the fuel type and grade, the volume of the furnace in which it is burned, the gasflow design of the furnace and boiler, and the operation and maintenance practices of the boiler users. The actual emissions on any given site will vary significantly.

If correct global costings are to be determined for the various conversion or mitigation solutions it is essential to be able to identify (in general terms) the appropriate range of technical solutions(s) for each type of boiler and burner. There is no “one size fits all” remedy.

The shaded areas in Table A5 identify the more likely combination of boiler and burner and provide the basis upon which the classification of the Canterbury boiler fleet has been made.

Some burner and boiler combinations already burn very cleanly. Particulate emissions (at the PM₁₀ size) associated with the combustion of gas are negligible (although there may be other emissions, particularly the oxides of nitrogen).

For other combinations, particularly those associated with coal there may be a number of ways of dealing with the emissions. Where there is a feasible method it has been identified with a number that refers to the list under “add-ons” or “conversions”.

In all cases the simple technical solution to particulate emissions from a dirty fuel is to move to a cleaner one and so the fuel conversion alternatives have not been included in Table A5. Likewise, in all cases, it may be possible to eliminate the need for a boiler entirely by a fundamental change in production or other methodology.

Table A5: Boiler Types and Emission Control Strategies

Boiler Construction	Coal/Wood				Oil			Gas (LPG)		Other Fuels
	Hand fired	Underfeed stoker	Drop Tube Stoker	Spreader Stoker	Pressure Jet	Air-Atomised	Rotary Cup	Pressure Jet	Naturally Aspirated	
Sectional		5,7,8			8, 11,13	8, 11,13				
Shell & tube, multi-pass (2, 3, 4)			7,8,9	7,8,9	8,9,10,11,13	8,9,10,11,13	8,9,10,11,13			
Shell & tube, reverse pass					8,9,10,11,13	8,9,10,11,13	8,9,10,11,13			
Vertical shell & tube		5,7,8			8,9,10,11,13					
Water tube				7,8,9	8,9,10,11,13	8,9,10,11,13	8,9,10,11,13			
Waste heat										
Tubular gas										
Condensing										
Abatement Strategies										
Conversions										
1 Fuel conversion - light distillate oil										
2 Fuel conversion - residual oil										
3 Fuel conversion - gas (LPG)										
4 Fuel conversion - waste oils (tallow, vegetable)										
5 Fuel conversion - wood pellets										
6 Fuel conversion - wood waste										
7 Basic changes in production methodology										
Add-Ons										
8 Cyclone grit arresters										
9 Bag filters										
10 Electrostatic precipitators										

11 Wet scrubbing										
13 Ceramic filtration										

Boilers

Sectional Boilers

As the name implies these boilers are made in sections from cast iron or steel. Within a given size of section, any number may be joined together to tailor the output of a boiler to a given need.

Sectional boilers are used almost entirely for the generation of Low Temperature Hot Water (LTHW) that is, water typically around 80°C. Such water may be used for central heating, domestic hot water generation, or process applications.

Sectional boilers are extremely versatile and can be fired on gas, oil, or solid fuels. As such, they make up the majority of the solid fuel boiler fleet and a significant percentage of the oil and gas fleet.

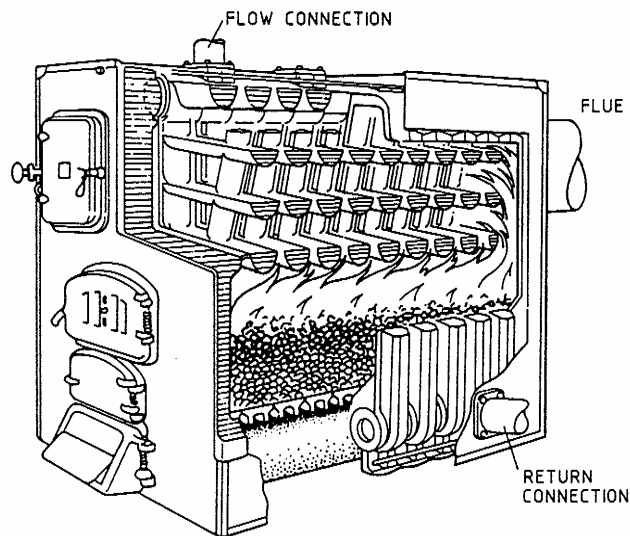

A typical hand-fired sectional boiler.

Shell and Tube boilers, multi-pass

The shell and tube boiler (also known as “fire tube” “smoke tube” or “package” boilers) derives from the steam locomotive boiler. Its outer jacket is a large steel cylinder (the shell), a smaller steel cylinder that contains the “fire”, and a large number of relatively small diameter tubes that provide a large heat exchange surface between the hot gases of combustion and the water contained by the shell.

Shell and tube boilers may be used for the generation of Low, Medium or High Temperature hot water (LTHW, MTHW, or HTHW) or steam up to pressures of 15 bar.

They are versatile, robust, and fuel efficient. The majority are oil or gas fired (for which they are particularly well suited). In the 1950's the Vekos Company in Holland adapted the design for automatic coal firing.

A diagram of a shell and tube boiler is shown on the following page.

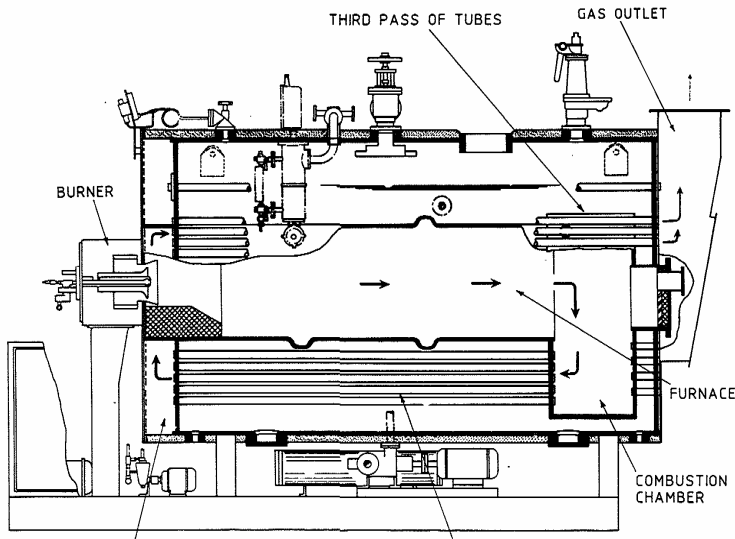

A typical "3-pass" shell and tube boiler. (So called because the hot combustion gasses make three "passes" through the boiler, the first being the combustion chamber, and the second and third being the tubes before being exited via the boiler flue.)

Shell and Tube Reverse Pass Boilers

Boilers of this type (also known as "thimble" or "reverse-flame" boilers) are very similar in construction to a multi-pass shell and tube boiler, saving that the first two passes happen within the combustion chamber.

The burner fires into a closed end combustion chamber, forcing the combustion gases to reverse within the chamber and move back against the flame before reversing again to exit via a single "pass" of tubes to the flue.

Such boilers are suitable for oil or gas firing only, although they may be used to generate all temperatures of hot water or steam up to about 15 bar.

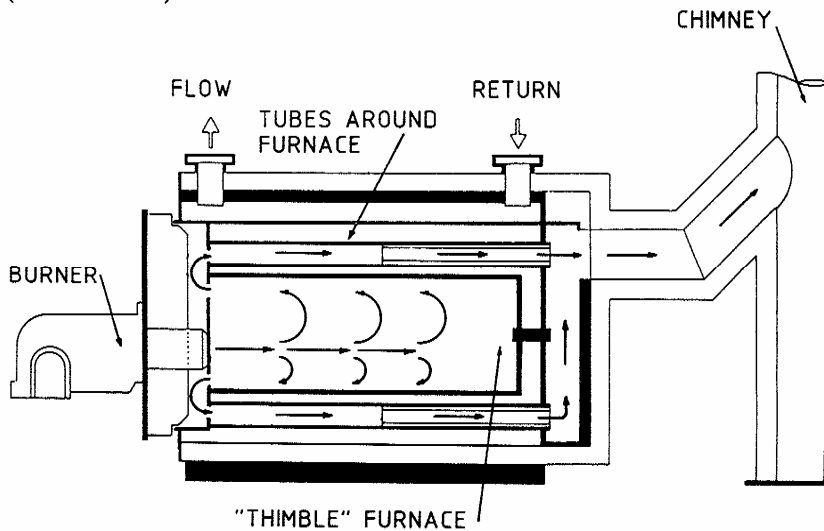

Vertical Shell and Tube.

The vertical shell and tube boiler is very similar to an ordinary horizontal shell and tube boiler, saving only that it is turned on its end. In some designs the tubes are turned vertically upwards.

Such boilers are generally smaller than a horizontal shell and tube design and are used in locations where space is limited.

Their shape makes them particularly suitable for solid fuel firing, although some are fired on oil or gas.

Again they may be used for LTHW, MTHW, HTHW, or steam.

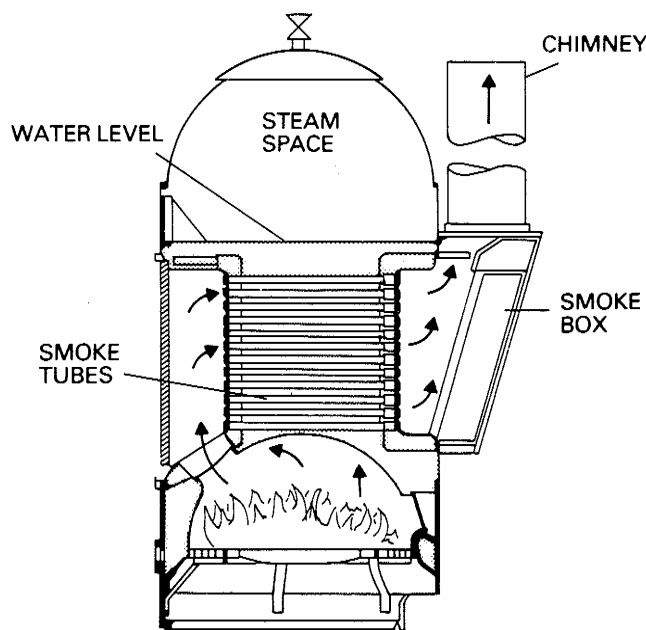

Water Tube Boilers

A water tube boiler is the reverse arrangement to a shell and tube boiler, in that water is contained inside of the tubes, and the fire or smoke on the outside.

There are many different designs and arrangements of water tube boilers (3-drum, forced circulation, natural circulation, and so on).

They are particularly suited to generating steam at high pressures (over 200 bar if required), in large quantities, and are the boiler of choice for power generation applications.

A diagram of a water tube boiler is shown on the following page.

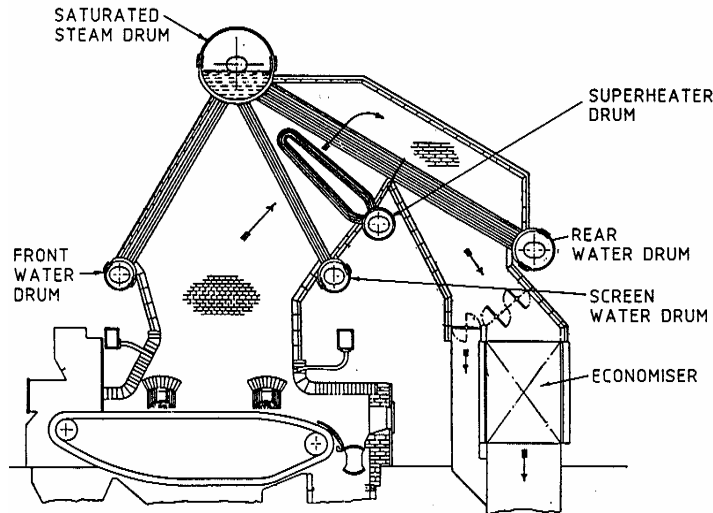

A typical 3-drum steam boiler. (The 3 drums being the front and screen water drums and the saturated steam drum). This particular example is fitted with a chain grate stoker, a superheater and an economiser, both of which require an additional drum over the basic boiler arrangement.

Waste Heat Boilers

Waste heat boilers may be of virtually any of the preceding patterns, depending on the heat source and the application to which the boiler is being put. Their distinguishing characteristic however is that they contain no heat source within. Their heat source is "waste" heat generated by an industrial process, from electrical generation or the like.



A typical waste heat boiler of the shell and tube pattern under construction. Note that there is no combustion chamber, only tubes.

Tubular Gas Boilers

This type of boiler operates on gas. It is very compact, efficient, and can respond very rapidly to alterations in load because of its very low water volume. In essence it is mass of copper, steel, or stainless steel tubes arranged over a burner.

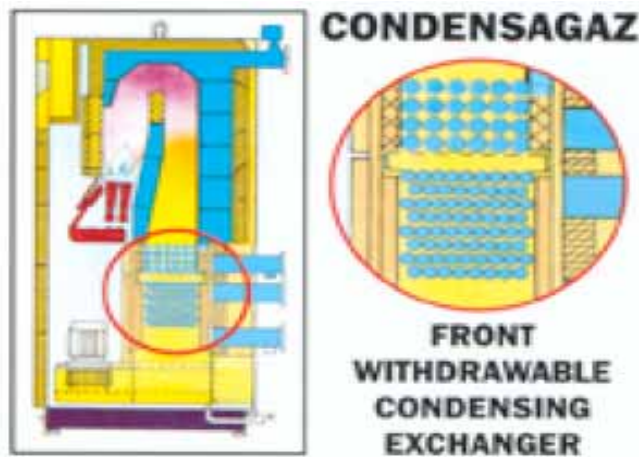

Condensing Boilers

Condensing boilers are generally small and virtually all are gas fired. They are the most efficient boilers in existence (97%+).

A boiler burns a fuel to create hot gasses, one of which is water vapour. A conventional boiler is designed to cool combustion gasses to just above the condensation point of the water of combustion⁶.

A condensing boiler is constructed from corrosion resistant materials so that it can safely extract the latent heat of condensation from the water of combustion, leading to an additional 10% or more thermal efficiency. By using gas a fuel, the combustion products are very clean and clearly defined, (essentially CO₂ and water vapour).

There are many variations in design of condensing boiler. The one illustrated opposite is essentially is three miniature boilers “ganged” together to create a single unit of about 225kW output.



⁶ The reason being that if the water of combustion condenses inside the boiler, other combustion gasses, notably CO₂ and SO₃ dissolve in the condensation to form carbonic and sulphurous acids which then corrode the boiler.

Burners

Underfeed Stokers

An underfeed stoker is a device that automatically transfers coal from a storage bunker into the combustion chamber of a boiler. It is almost always used in conjunction with a sectional boiler.

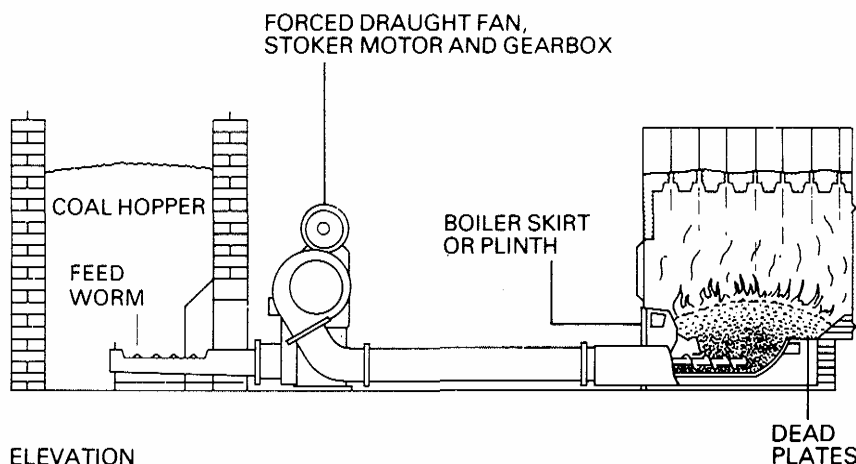

In essence, a slow speed auger moves small lumps of coal at a predetermined rate into a retort within the combustion chamber of the boiler. At the same time a fan blows air into the combustion chamber from both underneath the retort and into the flames above to achieve complete combustion.

When the boiler reaches its operating temperature, the fan and auger stop and the flames from the retort die down to a low smoulder until the temperature drops and the fan and auger re-start. In a few moments, the boiler again fires at full output.

The combustion ash remains inside the combustion chamber until such time as it is removed manually for disposal in a landfill.

Essentially, underfeed stokers are an on and off device and suitable for use in smaller boilers, up to a maximum of about 2000 kW.

A very useful recent development has been the use of underfeed stokers to burn wood pellets. Wood pellets are manufactured in Rolleston by Solid Energy and are made from ground untreated wood waste. Because they are dry, of uniform composition, and small size they can be made to burn cleanly and easily in the controlled environment of an underfeed stoker. This is demonstrated in Table A6 which compares emissions from the coal fired and wood pellet underfeed stoker (Keer-Keer & Bourke, et al, 2006).

The first underfeed stoker to be operated on wood pellets was at Rotorua Girls High in Rotorua. That installation has operated for two heating seasons now without difficulty. Since the 24th April two Christchurch schools have been operating on wood pellets, Central New Brighton School, and the Rudolf Steiner School. Emission testing has been carried out at Central New Brighton school before and after conversion. (At Central New Brighton, the boiler is a vertical shell and tube, and at Rudolf Steiner the boiler is a steel sectional boiler.)

Table A6: Comparison of emissions between coal and wood pellets.

	Coal (mg/m ³)	Wood Pellets (mg/m ³)
Particulate Matter	280	120
NO _x	333	81
SO ₂	1202	<17

Whilst nitrogen and sulphur emissions are outside of the scope of this report, they are nonetheless harmful. The use of wood pellets has a significant effect on both, nitrogen (presumably) because of a lower combustion temperature and a more evenly distributed combustion process, and sulphur because for all practical purposes, wood pellets are a sulphur free fuel.

Wood pellets have two further advantages; their use is carbon-neutral as they are a renewable resource, and the ash from combustion is a certified organic fertiliser.

Drop Tube Stoker

Whereas the underfeed stoker pushes fresh solid fuel into the combustion space from below, the drop tube stoker drops fuel into the combustion space from above.

This form of stoker is used almost exclusively by coal fired shell and tube boilers, (commonly known as "Vekos" boilers after their first maker, although a number of manufacturers make boilers of this pattern).

Coal is transported from a silo by an auger and then dropped into an airstream from above, scattering it into a heap in the centre of the combustion chamber near the front.

More air meets the fuel from below the grate bars upon which the fire sits.

As the fuel burns out, the ash falls through the grate to lay in the bottom of the combustion space until it is removed manually.

The downside of this method of combustion is the volume of fine particles that are carried off in the combustion gas stream as they fall from the coal feed tube to the burning coal below. The usual method of mitigation is the fitment of grit arrestors in the flue, and the passing back of the grits to the combustion space for re-firing.

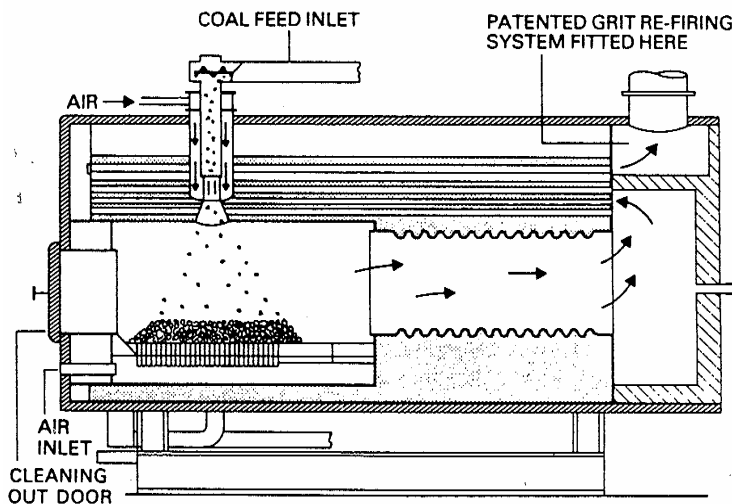

Spreader Stoker

The spreader stoker is similar to the drop tube stoker in that coal is fed from above the fire into the combustion chamber. Like the drop tube stoker it suffers from the same problem of fine particles being entrained in the combustion gas stream.

Again, they can be fitted with grit arrestor systems that will carry the entrained grits back from the flue gasses to the fire for re-burning.

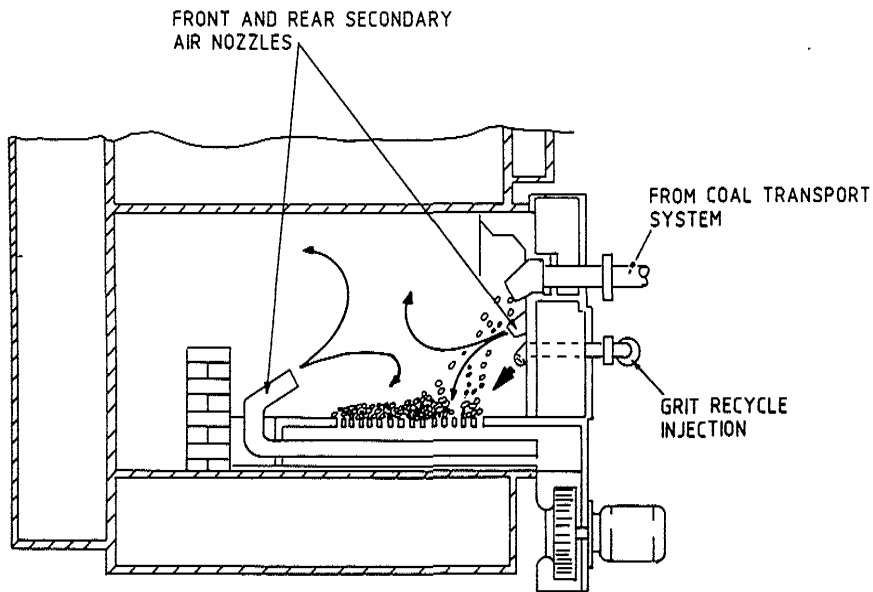

Chain-grate Stoker.

The chain grate stoker is another automated means of burning coal. In essence, a “conveyor” of chain links runs the length of the combustion chamber. Coal is fed onto the front of the chain in an even layer.

As the chain passes into the boiler, air is fed to the coal from above and below the chain and the coal burns, leaving the ash as the chain progresses along the combustion chamber.

Some ash falls through the grate to a conveyor belt below and some (together with any clinker) falls off the end of the chain onto the conveyor.

Such grates are common in large solid fuel boilers, and are capable of burning a wide variety of solid fuels, (provided they have a sufficient ash content.)

A diagram of a chain-grate stoker is shown on the following page.

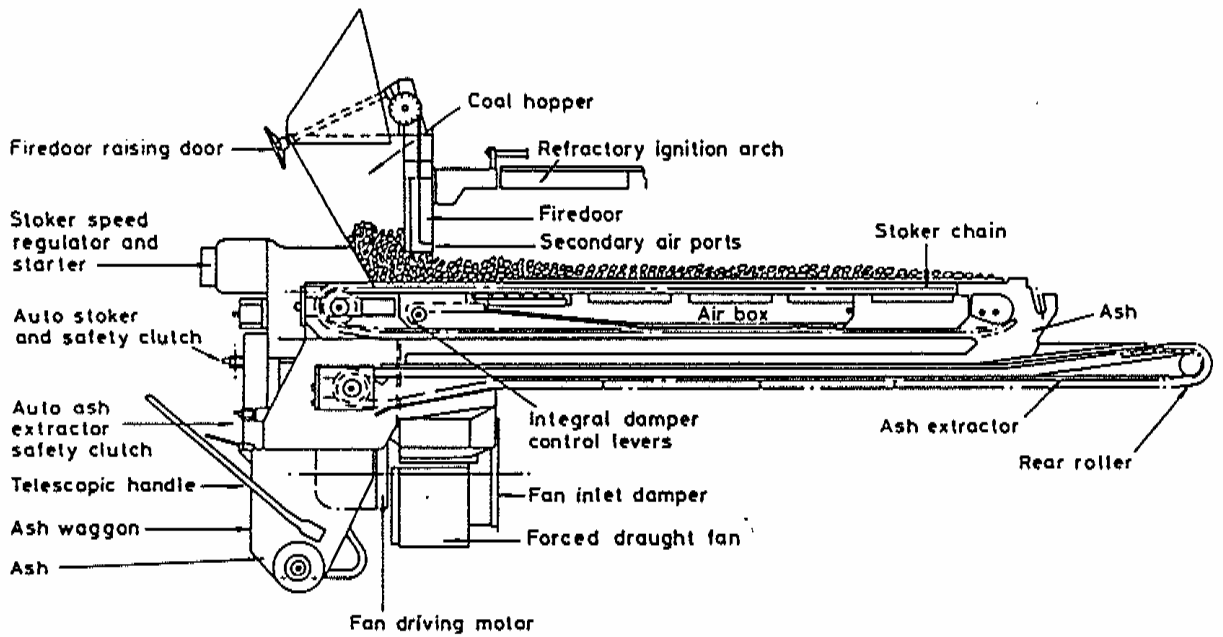

Pressure Jet Burner

A pressure jet burner is a means of burning oil, tallow, vegetable oils or other low to medium viscosity liquid fuels. It can burn all grades of oil from kerosene to light residual oils (although light residual oils may require that the oil be pre-heated beforehand).

Essentially, oil at high pressure is forced through a nozzle to cause it to break into fine droplets. The fine droplets are mixed with air from a fan that is integral with the nozzle and ignited to provide a stable flame.

Such burners are versatile and may be used with almost any boiler type.

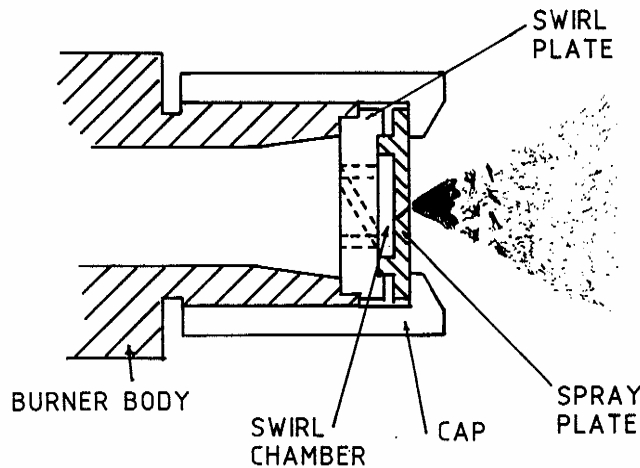

Air-atomised Burners

An air atomised burner uses a blast of compressed air (or steam) to atomise a flow of liquid fuel. Once atomised, the fuel meets additional combustion air and is ignited.

Such burners are compact in relation to their output, and, in addition to being used for boilers are used in many process applications. They are capable of burning virtually all liquid fuels.

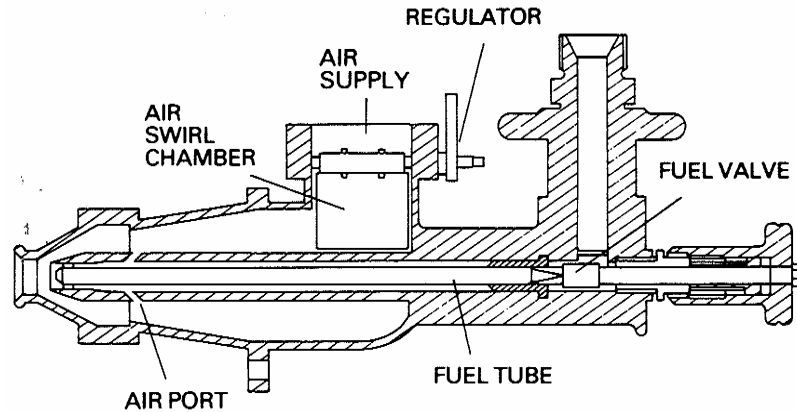

Rotary Cup Burners

The rotary cup burner is a very sophisticated, robust, versatile and controllable way of burning liquid fuels.

A rotary cup burner uses centrifugal force to atomise the fuel. A motor spins a hollow shaft at high speed. Fuel is forced down the shaft to the end where the shaft bells out into a "cup". The oil is spun out of the end of the cup as a fine mist where it meets the combustion air.

Rotary cup burners will burn almost all types of liquid fuel, but are particularly useful for burning the heavier grades of oil.

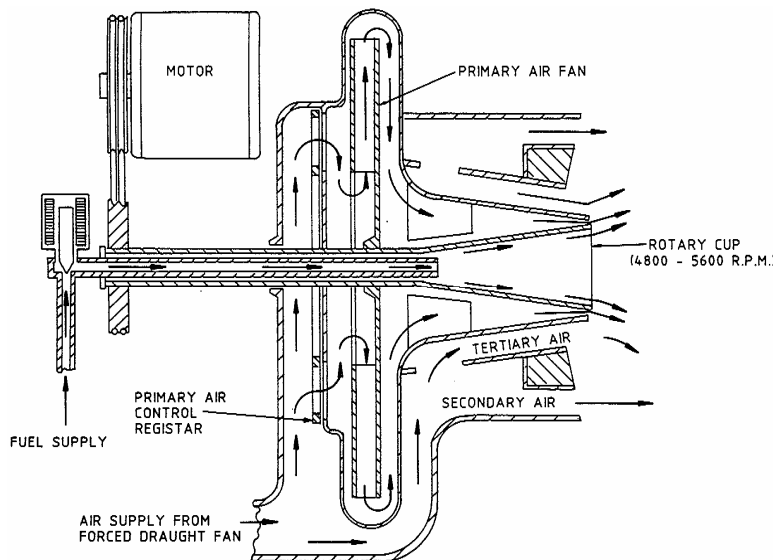

Pressure Jet Gas Burners

A pressure jet gas burner is very similar to a pressure jet oil burner (indeed, some can be dual fuel units, capable of burning oil or gas at the turn of a switch).

Gas is admitted through a small jet into the surrounding air stream in a manner analogous to the oil burner. In most applications, pressure jet oil or gas burners are interchangeable.

Naturally Aspirated Burners

This definition covers a wide variety of burner designs, the distinguishing feature of which is that they do not require any form of fan to achieve the mixing of the gaseous fuel with air. Naturally aspirated burners are more normally associated with the smaller sizes of boiler, typically in the size range that might be associated with domestic or small commercial applications. They are also widely used, often in large sizes for process applications.



A typical modular naturally aspirated burner.

Appendix G: Reducing boiler emissions

Operation and maintenance

Regular maintenance, cleaning, and periodic adjustment of combustion conditions make a significant and immediate reduction in the emissions of particulates. There are two mechanisms by which particulate reduction is achieved:

- a) Clean boilers and heat exchange surfaces mean less fuel has to be consumed to achieve the same heat output. Although not of significance in gas fired installations, it is very significant for coal fired plant and to some extent for oil fired, particularly that which uses residual fuel oils.
- b) If the combustion conditions are properly set, with just the correct amount of properly mixed fuel and air, the boiler will be operating in such a manner as to use the least amount of fuel and to minimise the generation of particulates that result from the incomplete combustion of that fuel. Boilers are rarely operated with too little air; that condition is readily apparent in the form of smoke, but they frequently operate with too much air which lowers the temperature of the resultant combustion gasses (and therefore reduces the efficiency of heat transfer), heats large volumes of air to no good purpose, and increases the velocity of gasses through the boiler increasing the total entrainment of particulates.

It is impossible to quantify with any accuracy the reduction in particulates from good housekeeping without considerable on-site investigation, but a reduction of at least 10% across the boiler fleet is probably not an unreasonable estimate.

Energy Efficiency Measures

From the authors' observation of a number of existing boilerhouses in Canterbury, particularly, but not only older coal installations), it is clear that they are seriously inefficient. Common problems include:

- a) Simple time switches bring boilers on and off at the same time every day, regardless of the weather or any real need. Many are so simple that they can only cope with weekdays and weekends, not holiday periods.
- b) Heating water is circulated out to heating systems at the same temperature regardless of weather.
- c) The end devices, (frequently radiators or convectors in the case of coal installations), are uncontrolled. The usual method of control is to open the window.
- d) Often, the heating distribution system is poorly insulated or the insulation has been allowed to deteriorate. This has been found to be the case particularly of some schools that have extensive underground mains.
- e) Systems are poorly zoned (i.e. split up into areas with similar control or usage characteristics). Frequently very large areas of a system are treated as one so that an entire area must be heated even if one room only requires heat.
- f) Older control systems have been torn out without replacement, been over-ridden, or just allowed to fall into disuse.
- g) Buildings have been refurbished internally to a good visual standard but have new internal layouts that have little to do with the arrangement and control of their heating systems. During building refurbishments, heating, ventilating, and control systems often have the bare minimum spent on them to allow their continued use.

In this day of increasingly sophisticated controls which in real terms continue to fall in price, it is very easy to go back to most systems and make simple retrofits that would eliminate items a, b and f.

Item c is usually more costly as it involves some pipework modifications, (although the control valves themselves are reasonably inexpensive).

Items d and e may range from a minor cost to major expenditure, depending on the particular situation.

Item g is a matter that could (perhaps) be dealt with during the building permit application stage. There ought to be a requirement for buildings that are undergoing a major refurbishment programme to meet current energy efficiency standards in operation (not just on paper), insofar as is reasonably practical within the limitations of the original building design.

It has been noted in the course of other work (outside of the scope of this study) that many boiler systems have overall efficiencies between the incoming fuel and the final point at which heat is used of the order of 50%. At least 75% should be regarded as the minimum acceptable, and better than that (for more modern systems) is easily achievable.

As in the case of good housekeeping, it is impossible to quantify the savings that could be achieved through energy efficiency measures without the detailed evaluation of a significant number of sites, but a 20% reduction in particulate emissions from eliminating unnecessary fuel burn ought to be achievable for most older boiler installations (and quite a number of relatively recent ones too.)

Fuel Conversions

In many cases the simplest and cheapest way of overcoming a particulate emission problem is to change fuels. Almost all solid fuel boilers can be adapted to operate on oil or gas, and most oil fuelled installations can be changed to gas.

Coal to Light Distillate Oil (also known as Diesel or Number 2 Oil).

This also applies to a conversion to tallow, vegetable oils and the like.

The essential scope of work for a conversion to light distillate oil (diesel) or tallow/vegetable oil would be:

- Removal of the existing stoker
- Sealing of any openings
- Repair of any internal refractory linings
- Manufacture of an adapter plate to carry a burner (typically a pressure jet unit)
- Installation of an oil tank in an accessible location
- A new control panel

Generally this is a simple conversion.

Converting to light distillate oil will typically result in particulate emissions of around 20mg/m³.

At least two oil-fired boilers in Christchurch have recently been converted to burn tallow reclaimed from meat processing. Emission testing at one of these sites measured a small particulate matter emission rate of less than 0.1g per litre oil burned, less than half the emission rate from diesel oil indicated by USEPA emission factors (Iseli, 2007, pers comm.).

Coal to Light Fuel Oil

The scope of work would be similar to that required for light distillate oil, saving that for larger installations a rotary cup burner might be chosen, and that in any location that experienced particularly cold temperatures trace heating of the oil supply lines and pre-heaters may be required to keep the oil viscosity low enough for combustion.

In addition to converting the fuel additional filtration may be required, either a bag house or ceramic installation.

The achievable emission rates would be:

- Conversion to LFO 100mg/m³
- Conversion + bag house less than 50mg/m³
- Conversion + ceramic filters less than 50mg/m³

Coal to Wood Pellets

A typical scope of work would be:

- A complete clean out of the coal bunker, stoker, and boiler.
- Modification (in some cases) of the bunker to ensure the free flow of wood pellets to the stoker. (A properly designed coal bunker requires no modification, but many are not properly designed.)
- Careful sealing and flashing off of the bunker doors to ensure no possibility of water entry.
- Sealing of the bunker internal surfaces if there is any sign of ground water seepage.
- Fitment of a variable speed drive to control the stoker auger screw
- Modification of the overfire / underfire air supplies to ensure correct combustion on wood pellets.
- A final “re-commissioning” and emissions check on wood pellets.

Specific to each location there may be other works required.

Given the lack of site specific information at this time, it is difficult to be 100% certain of the emission results. However, it is known for sure that 100mg/m³ is being achieved at Rotorua Girls High, and that the resource consents for Central New Brighton and Rudolf Steiner Schools were granted at 125mg/m³, although site tests suggested that when properly set up the Central New Brighton installation was probably capable of 80mg/m³.

At this time, it is reasonably safe to say that around 100mg/m³ is achievable for wood pellet installations. However, it would be wise to monitor a number of sites with different types and arrangements of equipment, over a period of time, to generate reliable long term average operating data.

Coal to Wood Waste

The scope of work for a coal to wood waste conversion is very similar to a wood pellet conversion. Wood waste however is not as intolerant of moisture ingress as are pellets.

Coal to Gas (LPG)

The conversion of coal to gas is virtually identical to the conversion of coal to light distillate oil, saving only that space must be found for either a gas bottle rack, or for larger installations, a gas storage tank. Some locations however, particularly central city areas, may have access to piped gas.

Light Fuel Oil to Light Distillate Oil

The conversion of light fuel oil to light distillate oil is a very simple change that involves no more than filling the tanks with light distillate oil and a re-tune of the burners to ensure correct combustion.

Particulate emissions will drop from around 100mg/m³ to around 20mg/m³ and SO₂ will be significantly reduced.

Oil to Gas

The scope of work for conversion from oil to gas would be:

- Remove the existing oil burner and storage tanks.
- If it is a pressure jet burner, replace the burner with the equivalent gas model.
- Install a gas train. (The group of valves and control devices required for safety and isolation).
- Installation of a gas bottle rack, gas storage tank, or connection to the gas supply network.
- Re-commissioning on gas.

Heat Pumps

The output of a large proportion of all boilers is used for space heating. An alternative option for a significant number of boiler operators is to cease boiler operation altogether and switch to heat pumps.

Heat pumps are used widely in domestic and small commercial operations, but today there is no reason why heat pumps cannot be used in buildings of any size. Heat pumps are economical propositions in any space heating application, or where water is required at temperatures of up to 45^oC (50^oC in some cases). They have a number of advantages.

- They are very flexible. Very small spaces can be used without the need to operate any central plant, leading to significant energy savings.
- They are the most energy efficient alternative available, with the lowest energy costs in most applications.
- Depending on the source of electricity, they can be carbon neutral a renewable resource.

On the down side however;

- They do not last as long as boiler plant. Typically a heat pump installation would have a 15 year life, where a boiler plant would be 30 years or more.
- They are entirely dependent on an electrical supply. Given that New Zealand's electrical demand continues to outstrip the installation of new generating capacity, and given that the existing capacity depends to a very great extent on the vagaries of the weather, the wisdom of relying on heat pumps is questionable. Certainly there will be a number of applications where any uncertainty over fuel supply would be unacceptable (for example; hospitals and other institutions, some commercial or public operations, or the like).

Add-On's

The environment of a boiler exhaust is a tough one for filters and materials to survive in. Typically it is hotter than 160^oC, humid, and contains potentially corrosive NO_x, SO_x and CO_x materials, not to mention particulates, some of which can (depending on what they are) be quite cohesive.

Although considerable research and development has been undertaken around the world over a long period into cleaning up the emissions from coal, most of that work has been directed to burning it on an industrial and power generation scale. There are a very limited number of technologies available which are potentially applicable to small and medium sized boilers.

To quote from the International Energy Agency, an industry organisation funded by governments to promote the sustainable use of coal, "Such boilers (stoker, chain grate, spreader stoker and the like) are commonly used in sizes equivalent to 10-25 MWe, but emissions control tends to be uneconomic from such units, apart from the use of cyclones for particulates removal. Combustion is relatively unstable, so that there can be intermittent emissions of CO, NOx and organics".

A similar quote from a 2006 report by the Finnish Funding Agency for Technology (TEKES) states that:

"Overall, the FINE programme confirms that there is a clear window of opportunity for innovation in combating particulate emissions in energy generation and industry given the ongoing requirement for more efficient boilers and better filter technology, resulting both from the introduction of ever tougher emission limits and the limitations of existing solutions.

This is particularly clear in respect of small plants rated below 10MW for which no cost-efficient fine particulate control technology exists as yet - something that is highlighted by the fact that fine particulate emissions from larger energy generating facilities are low compared with those from small scale wood combustion."

Nonetheless, technically, the following particulate reduction "add-ons" are applicable, and some, such as bag filtration are being used.

Cyclones

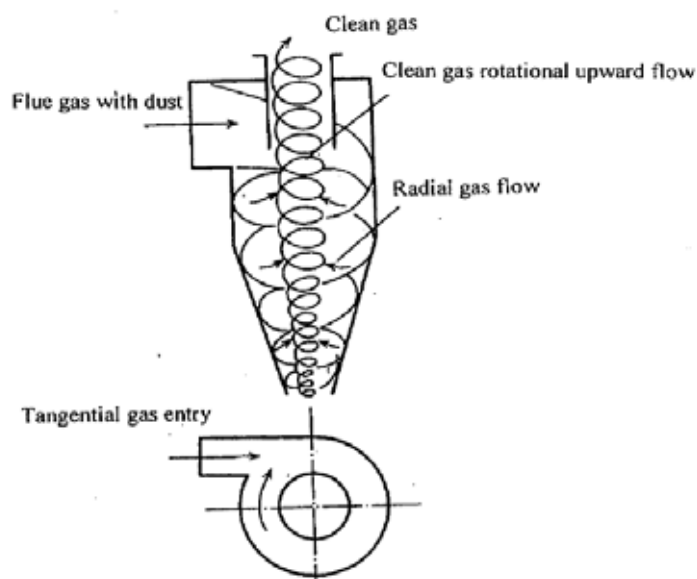

A cyclone is a device that causes the exhaust gasses to move in a tightly circular path and in so doing causes entrained particles to be thrown to the sides of the cyclone and fall to the bottom, from where they may be removed.

The principle of operation is well illustrated in the diagram below.

To improve the collection efficiency, a number of cyclones may be placed in series, creating the so-called multi-cyclone, a device commonly used in drop tube boilers. Cyclones of this pattern are a simple and reliable way of reducing emissions.

Table A7 shows typical emissions of particulate matter from coal combustion plants using cyclones:

Table A7: Typical emissions of particulate matter from coal conversion plants using cyclones.

	Emission factor TSP (kg/tonne of coal)	Particulate loading TSP (mg/m ³)
Spreader and drop tube	6.2	650

stokers ("Vekos") with internal cyclone only		
Chain grate stokers with multiple cyclone	2.1	220
Underfeed stokers with multiple cyclone	1.9	200

Cyclones are effective at removing the larger sizes of particles, but are less effective at removing particles of 10 micron (PM₁₀) or less.

Wet Scrubbing

Wet scrubbers force the flue gasses to pass through fine water sprays. The particulates, along with a significant proportion of any soluble gasses such as SO₂ are entrained in the water. The wet gasses then pass through a cyclone separator to remove the particle containing water droplets.

A proportion of the water is then passed through a clean up process before it is discharged as waste.

Table A8 shows the typical emissions from coal combustion plants using wet scrubbers:

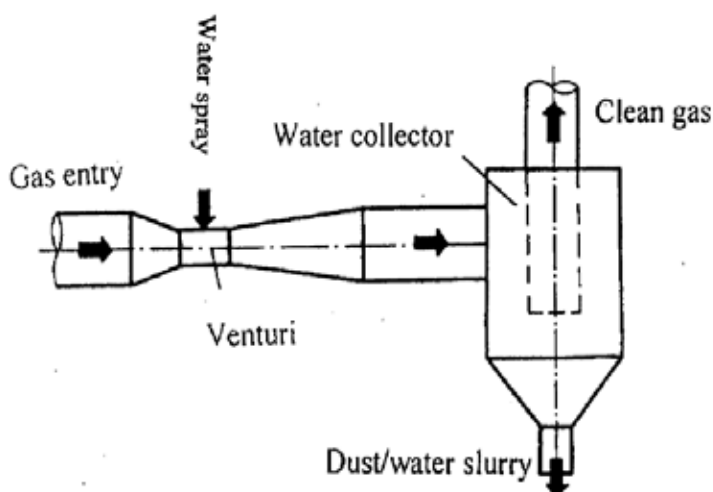
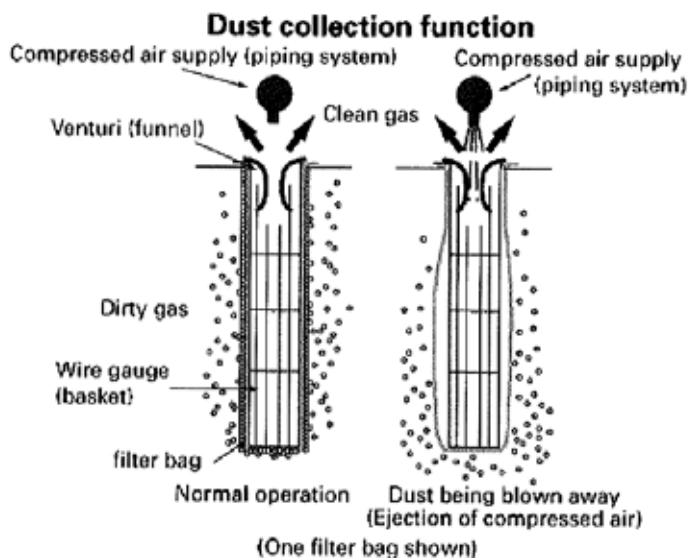

Table A8: Typical emissions from coal combustion plants using wet scrubbers.

	Emission factor (kg/tonne of coal)	Particulate loading (mg/m ³)
Spreader and drop tube stokers ("Vekos")	1.2	120
Chain grate stokers	1.0	100
Underfeed stokers	1.0	100

Bag Filters

Bag filters are made from a variety of fabrics, normally nylon, polyethylene or polypropylene. Typically they will operate at temperatures up to 240°C, or 280°C with teflon or glass fibre bags.



The flue gasses pass from the outside of the bags to the inside. When the pressure drop between the inside and outside of the bag becomes too great, the bag is shaken, either mechanically or by injecting a pulse of compressed air inside

the bag. The collected particulates are collected from the bottom of the baghouse for disposal.

Table A9: Theoretically achievable emissions from coal combustion plant using bag filters

	Particulate loading (mg/m ³) (see next 3 paragraphs)
Spreader and drop tube stokers ("Vekos")	5
Chain grate stokers	5
Underfeed stokers	5

It will be noted in the data that is presented for bag filters in real operation that the actual measured particulate levels are of the order of 10 times greater than those in Table A9. There are two reasons for this.

First, in some cases the bag filters are arranged to filter only a percentage of the total gas flow. This is a commonplace arrangement in many installations around the world. Second, is that if bags and baghouses are not well maintained their performance deteriorates. There is no guarantee that those installations that have been monitored for particulate performance were working at their best efficiency.

Measurements of boiler plants fitted with bag filters in New Zealand have typically recorded particulate matter emission concentrations of 20-50mg/m³. Greater or lesser emission rates may be achieved depending upon the choice of filter media.

Electrostatic Precipitators

Electrostatic precipitators pass the boiler flue gasses through very high voltage electrostatic fields causing the particulates to precipitate out on the electrostatic plates, from which they are removed either mechanically, or by a water spray.

Water spray precipitators are much easier in operation, but can only be used at temperatures of 180°C maximum, rendering them inappropriate for many applications. At temperatures above 180°C dry precipitators are used.

Electrostatic precipitators are the device of choice at very large sizes (power stations), but are very expensive at smaller sizes.

Achievable emission rates are around $20\text{mg}/\text{m}^3$ although data from their use in industrial and commercial installations is very limited.

Ceramic Filters

Ceramic filters in operation are very similar to bag filters saving that they use a hollow ceramic tube as a filtration device.

In a typical installation, large numbers of ceramic filter elements are arranged to operate in parallel. Gasses pass from the outside to the inside of the element, with the particulates adhering to the outside.

When the differential pressure across a group of elements reaches a pre-determined maximum, a pulse of compressed air is injected into the hollow centre of each element, knocking the accumulated particulates off to the bottom of the filter assembly from where they can be collected.

Ceramic filters are particularly suitable for hot corrosive environments, as high as 425°C .

The downside however is that, (apart from being costly), the elements are relatively fragile and prone to breakage. Should a single element in a ceramic filter assembly fail, the entire assembly ceases to function.

Achievable emission rates with ceramic filters are claimed to be around $5\text{mg}/\text{m}^3$, although it must be stressed that there are no known installations of ceramic filters in New Zealand (or anywhere else that we are aware of) in association with coal boilers.

Future Possibilities

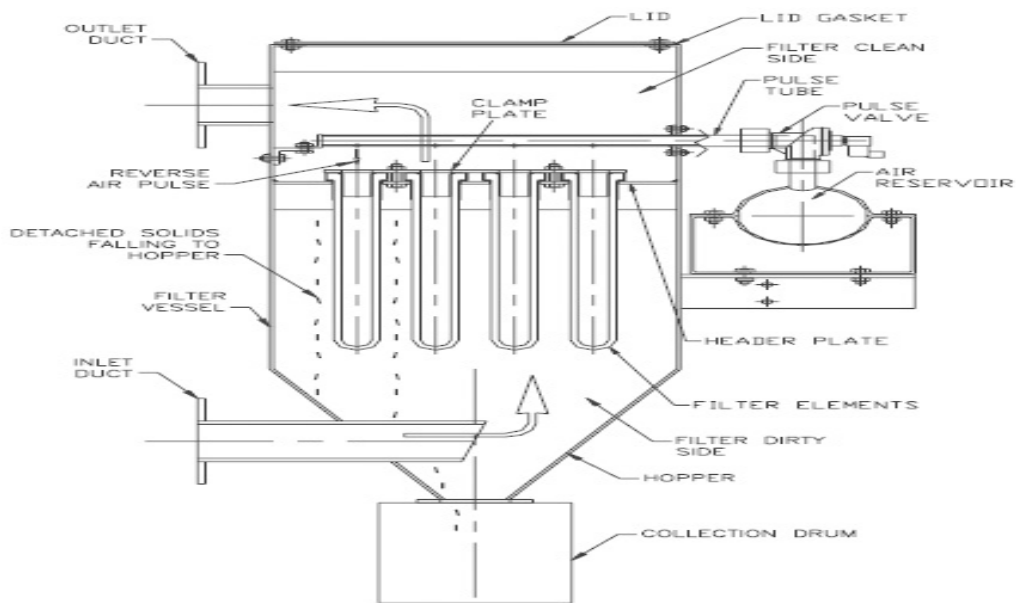

Ga

s
i
f
i
c
a
t
i
o
n

An exciting alternative that is

about to become available in New Zealand is biomass gasification. Gasifiers have been around for a long time (an example includes pictures from WWII of motor vehicles with something that looked like a pot-belly stove perched on the rear bumper). The current technology is Indian in origin (Ankur Scientific Energy Ltd.). More than 900 units are claimed to be in operation already. A New Zealand company (Autotech Engineering Ltd.) has taken the New Zealand manufacturing rights and expects to commission its first plant within the next 3 months.

The most exciting element of the gasification technology is that the gasses can be used in local co-generation by the simple expedient of taking the gasses to an engine (reciprocating in the smaller sizes, gas turbines at larger outputs). The engine exhaust and cooling systems still leave large volumes of heat for process applications, either as hot gasses, hot water or steam depending on the particular application.



The illustration above shows a 400kW gasifier, with a diagram that explains the essence of the process.

The gasifier itself burns the biomass to release the combustible gases from the remainder and to convert the fixed carbon in the wood to carbon monoxide, leaving the majority of the energy to be cleaned via a ceramic filter and taken to a gas engine.

In the smaller sizes such gas engines are typically reciprocating units, and in the larger sizes gas turbines.

The overall system efficiency is comparable to an industrial boiler at around 75%. The key difference however is that somewhere between 24 and 28% of the thermal energy appears as much more valuable and useful electricity. Particulate emissions are claimed to be very low indeed, less than $1\text{mg}/\text{m}^3$ at the outlet from the gasifier.

Gasifiers are to be made available in sizes from 10kW electrical to 2.2MW electrical. If only the heat is required, then the output is from 30kW to 5.5MW.

The thermal balance for a gasifier of 250kW electrical output is illustrated in the diagram below. Of the energy input, 24.6% is recovered as electricity, and 46% as heat.

OVERALL THERMAL BALANCE FOR THE GAS-250

